

Best Available Copy

(12) INTERNATIONAL APPLICATION PUBLISHED UNDER THE PATENT COOPERATION TREATY (PCT)

(19) World Intellectual Property Organization
International Bureau



(43) International Publication Date
28 December 2000 (28.12.2000)

PCT

(10) International Publication Number
WO 00/78917 A1

- (51) International Patent Classification⁶: C12M 1/00, G01N 33/543, 33/551, 33/552, 33/553
- (21) International Application Number: PCT/US00/13056
- (22) International Filing Date: 12 May 2000 (12.05.2000)
- (25) Filing Language: English
- (26) Publication Language: English
- (30) Priority Data:
09/335,732 18 June 1999 (18.06.1999) US
PCT/CA99/01079 12 November 1999 (12.11.1999) CA
- (71) Applicant (for all designated States except US):
UMEDIK, INC. [US/US]; Suite 1700, 90 Park Avenue, New York, NY 10016 (US).
- (72) Inventor; and
(75) Inventor/Applicant (for US only): LEA, Peter [CA/CA]; 360 Greer Road, Toronto, Ontario M5M 3P5 (CA).
- (74) Agents: DOYLE, Charles, M. et al.; Lyon & Lyon LLP, One North Lexington Avenue, White Plains, NY 10601 (US).
- (81) Designated States (national): AE, AG, AL, AM, AT, AU, AZ, BA, BB, BG, BR, BY, CA, CH, CN, CR, CU, CZ, DE, DK, DM, DZ, EE, ES, FI, GB, GD, GE, GH, GM, HR, HU, ID, IL, IN, IS, JP, KE, KG, KP, KR, KZ, LC, LK, LR, LS, LT, LU, LV, MA, MD, MG, MK, MN, MW, MX, NO, NZ, PL, PT, RO, RU, SD, SE, SG, SI, SK, SL, TJ, TM, TR, TT, TZ, UA, UG, US, UZ, VN, YU, ZA, ZW.
- (84) Designated States (regional): ARIPO patent (GH, GM, KE, LS, MW, SD, SL, SZ, TZ, UG, ZW), Eurasian patent (AM, AZ, BY, KG, KZ, MD, RU, TJ, TM), European patent (AT, BE, CH, CY, DE, DK, ES, FI, FR, GB, GR, IE, IT, LU, MC, NL, PT, SE), OAPI patent (BF, BJ, CF, CG, CI, CM, GA, GN, GW, ML, MR, NE, SN, TD, TG).
- Published:
— With international search report.
- For two-letter codes and other abbreviations, refer to the "Guidance Notes on Codes and Abbreviations" appearing at the beginning of each regular issue of the PCT Gazette.

(54) Title: DEVICE AND METHOD FOR ANALYZING A BIOLOGIC SAMPLE

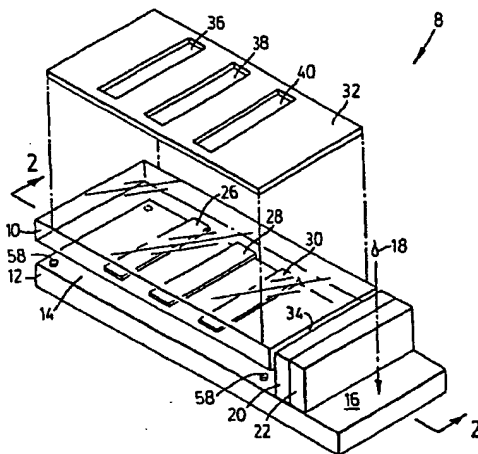

(57) Abstract: A device for separating fluid from a biological sample when the sample has a fluid and a non-fluid component is described. A method for separating fluid from a biological sample is also provided wherein the method comprises the step of bringing the fluid sample in fluid contact with the microspheres such that the fluid component moves by capillary action between the microspheres along capillary channels transiently formed in the spaces between the microspheres and leaving the non-fluid component behind. In the methods of the present invention, the step for separating the fluid may be combined with other assay techniques for detecting and/or measuring one or more analytes which may be present in the fluid sample, such as immunoassays and chromatographic assays. These may be further combined with groups of microspheres for use in the analyte detection step as well as the separation step whereby the microspheres act as labels for the analyte or as a source of label for the analyte.

WO 00/78917 A1

DEVICE AND METHOD FOR ANALYZING A BIOLOGIC SAMPLE

This application is a continuation-in-part application of copending PCT Patent Application No. PCT/CA99/01079, the entirety of which is hereby incorporated by reference.

5

Field of the Invention

This invention relates to a device for separating a fluid component, such as plasma, from a non-fluid component of a biologic sample, such as blood, using suitable small particles such as microspheres. The term "microspheres" as used herein means spheres or particles of sizes ranging up to 5,000 μm in mean diameter, preferably up to 50 μm in mean diameter. This invention also relates to a device and method for quantitative determination of an amount of analyte present in biologic fluids that employs such small particles to separate a fluid component containing the analyte from a non-fluid component. The invention further relates to a quantitative assay method and device for measuring one or more analytes in a biologic fluid sample using a point-of-care assay method and device.

In one embodiment, the sample could be a suspension or solution which is prepared for the purpose of testing for the presence and, optionally, the amount of one or more micro-organisms. In another embodiment, the sample could be a suspension or solution which is prepared for the purpose of testing for the presence and, optionally, the amount of one or more proteins. The proteins could be, for example, an antibody or an antigen. The test results can be analyzed using a suitable analyzer and, optionally, the assay test results are transmitted by way of digital transmission

systems to permit further evaluation of the data. The data generated in this manner may be used to create databases suitable for diagnostic or prognostic purposes.

Background of the Invention

5 There are presently many examples of one-step assays for measuring analytes in fluids. A common assay is the pregnancy test device, which involves contacting a urine sample with a test pad, comprising a bibulous chromatographic strip containing reagents capable of reacting with and/or binding to of human chorionic gonadotropin (HCG). The urine sample moves by capillary flow along the bibulous
10 chromatography strips and the presence of HCG is detected, usually as shown by a coloured line, because of the reaction between HCG and the reagents in the bibulous chromatography strips. This is an example of a chromatographic assay.

U.S. Patent 5,766,961 issued June 16, 1998 and U.S. Patent 5,770,460 issued June 23, 1998 are both entitled "One-Step Lateral Flow Nonbibulous Assay".

15 "Nonbibulous lateral flow" refers to liquid flow in which all of the dissolved or dispersed components of a liquid, which are not permanently entrapped or filtered out, are carried at substantially equal rates and with relatively unimpaired flow laterally through a stabilized membrane. This is distinguished from preferential retention of one or more components as would occur, for example, in materials capable of
20 absorbing or imbibing one or more components, as occurs in chromatographic configurations. In this one-step assay, a sample (which may contain the analyte of interest) is collected on the "sample receiving zone" from which it flows to the "labelling zone" at which point it encounters a specific binding reagent for the analyte

coupled to visible moieties (the "assay label"), then flows to a "capture zone" where the analyte bound to visible moieties is captured.

In U.S. Patent 5,540,888 issued July 30, 1996 and entitled "Liquid Transfer Assay Devices", the invention described is a device for biochemical diagnostic assays.

5 It comprises two liquid flow channels of porous material which transfer liquid by capillary flow to a common site following simultaneous application of the liquid to the ends of the channels. The channels interconnect at a certain point and then both continue in an arrangement analogous to an electrical bridge circuit. By selecting the hydraulic resistances of the arms of this circuit, the flow can be controlled across the
10 bridge.

U.S. Patent 5,300,779 issued April 5, 1994 entitled "Capillary Flow Device" describes methods and devices for measuring an analyte in a sample mixed with reagents, the devices defining a flow path. The specific binding by agglutination may provide for changes in flow rate, light patterns of a flowing medium, or light
15 absorption or scattering which permit measurement of the analyte of interest.

In U.S. Patent 5,110,724 issued May 5, 1992, entitled "Multi-Analyte Device", the invention described is an assay device for assaying multiple analytes in a drop-sized blood sample. A dispenser distributes a small volume blood sample to multiple transfer sites by capillary flow of the blood sample through sieving and distributing
20 matrices which separate blood cells from plasma as the sample fluid migrates toward the transfer sites. A test plate in the device carries multiple absorbent pads, each containing reagent components for use in detection of a selected analyte. The test plate is mounted on the dispenser toward and away from a transfer position at which the exposed surface regions of the pads are in contact with associated sample-transfer

sites, for simultaneous transfer of sample fluid from such sites to the pads in the support.

In U.S. Patent 5,039,617 entitled "Capillary Flow Device and Method for Measuring Activated Partial Thromboplastin Time", the invention described measures
5 "activated partial thromboplastin time" (APTT) on a whole blood sample by applying the sample to a capillary tract with reagents capable of initiating an APTT analysis, wherein clotting time is measured by the cessation of blood flow in the capillary tract. This is an example of a risk evaluation based on coagulation.

In U.S. Patent 4,753,776 entitled "Blood Separation Device Comprising a
10 Filter and a Capillary Flow Pathway Exiting the Filter", the invention describes a method for separating plasma from red blood cells. The driving force for the movement of plasma from the filter to the reaction area of a device utilizing the method is capillary force provided by a tubular capillary. A filter is selected from glass microfiber filters of specified characteristics.

15 In U.S. Patent 5,135,719 issued August 4, 1992, entitled "Blood Separation Device Comprising a Filter and Capillary Flow Pathway Exiting the Filter", the similar invention is described and the glass fibre filters are prepared from fibers with diameters between 0.10 and 7.0 μm .

In U.S. Patent 4,447,546 issued May 8, 1984, entitled "Fluorescent
20 Immunoassay Employing Optical Fibre in Capillary Tube", a short length of precise diameter capillary tubing with an axially disposed optical fibre to which is immobilized a monolayer of a component of the antibody antigen complex (eg. an antibody) is described. The tubing is immersed in the sample.

U.S. Patent 5,610,077 issued March 11, 1997, entitled "Processes and Apparatus for Carrying Out Specific Binding Assays", describes the well known antibody/antigen binding assay. The sample which may contain the analyte (a), (the substance being tested for) is mixed with (b) an antibody which binds to the substance
5 being tested for, which antibody is immobilized on a solid support, and (c) another antibody for the substance being tested for which is conjugated to a detectable marker, to thereby form a complex between (b), the substance being tested for and (c) and causes the marker to be immobilized and detected.

In U.S. Patent 4,943,522 issued July 24, 1990, entitled "Lateral Flow, Non-
10 Bibulous Membrane Assay Protocols", the described invention is a method and apparatus for conducting specific binding pair assays, such as immunoassays, the test substrate is a porous membrane on which a member of the binding pair is affixed in an "indicator zone". The sample is applied and is permitted to flow laterally through the indicator zone and any analyte in the sample is complexed with the affixed specific
15 binding member, and detected. A novel method of detection employs entrapment of observable particle in the complex, for instance, red blood cells of blood can be used as the observable particles for detection of the complex.

An example of a method to separate red blood cells from whole blood samples is found in U.S. Patent 5,118,428 issued June 2, 1992, entitled "Method to Remove
20 Red Blood Cells from Whole Blood Samples". In the described invention, red blood cells are removed from whole blood samples with a solution containing an acid. The agglutinated red blood cells are then removed from the resulting suspension by procedures of filtration, centrifugation or decantation, leaving an essentially red blood cell-free serum or plasma sample.

In U.S. Patent 5,073,484, entitled "Quantitative Analysis Apparatus and Method", an analyte is measured along a liquid flow path which includes a number of reaction-containing reaction zones spaced apart along the flow path. Detector means are employed to detect analyte, reactant or predetermined product in the reaction
5 zones, the number of zones in which detection occurs indicating the amount of analyte in the liquid.

In U.S. Patent 5,536,470 issued July 16, 1986, entitled "Test Carrier for Determining an Analyte in Whole Blood", red blood cells cannot gain access from the blood sample application side, to the detection side and on the detection side as a
10 result of an analysis reaction, an optically detectable change occurs.

A serious deficiency in current one-step assays for the measurement and/or detection of an analyte is that they provide only qualitative results rather than quantitative results. That is to say that the presence or absence of the analyte may be determined but the actual amount or concentration of analyte present in the sample
15 would still not be known. The assay of the present invention provides quantitative results as the test is performed in a determinable volume. In the prior art methods it is not possible to consistently identify the exact volume of the test sample in repeated testings since the fluids must wash through the test strips.

In addition to the inability to quantify the results, prior art methods using
20 chromatographic strips and fiberglass strips require larger initial volumes of the biologic fluid in order to mobilize the proteins and labels in the strips. This is particularly true when the biologic fluid is blood and the plasma must first be separated from the blood sample. An advantage of the device and method of the present application is that very small fluid samples can be used to measure one or

more analytes. The assay method and device of the present invention is also advantageous because the test volume can be made constant and therefore repeated testings will yield quantitative data which can be directly compared between samples and within a sample.

5 It is an advantage of the present invention that the assay device and methodology allows for separation of the fluid component, such as plasma from the non-fluid component of a sample, such as whole blood, during the assaying of the fluid sample. In other words it is not necessary to previously separate out the cellular component of the blood before assaying the sample. This is a significant advantage as
10 it allows the assay to be used at the point of patient care, for example, by the patient, at the patient's bedside or in a doctor's office. In a preferred embodiment of the present invention there is provided by the device and assay methodology of the present invention a generic point-of-care platform suitable for use in one or more diagnostic or prognostic assays performed on one or more fluid samples.

15

Summary of the Invention

In accordance with an aspect of the present invention a method for separating out the fluid component of a biologic sample is provided. In one embodiment, the biologic sample is placed in contact with a group of microspheres and the fluid
20 component separates from the sample as the fluid portion flows through the microspheres, by capillary action. In a preferred embodiment, the microspheres are of a defined diameter or size. In another embodiment particles of non-uniform size and/or shape may be used to separate a fluid portion from a biologic sample instead of using microspheres.

In accordance with an aspect of the present invention a quantitative assay method and device are provided for measuring one or more analytes in a fluid sample using a point-of-care assay method and device. The assay and device are designed for use by a patient, at the bedside of a patient, or in a doctor's office. The test results are analyzed using a suitable analyzer and, optionally, the assay test results are transmitted by way of digital transmission systems to permit further evaluation of the data by an off-site professional.

The microspheres, or other particles, act as a dynamic filter to extract or partition a fluid portion away from the non-fluid portion. The channels and the contacts between the particles may be transient since the beads exhibit motion during the separation step. Therefore the rapid, instantaneous capillary extraction is by a dynamic capillary filter created by the transient capillary channels formed by the interstitial spaces between the microspheres or particles.

In accordance with an aspect of the present invention, an assay method and assay device are provided for testing small volumes of fluid samples, such as biologic fluids, including blood, in a timely manner. The assay device is preferably a portable assay device. In accordance with another aspect of the present invention, a method and device are provided for testing biologic fluid samples in which a consistent volume of the biologic fluid sample is tested for one or more analytes and the data generated from the tests are used for collecting and compiling in a database pertaining, for example, to a particular disease condition. Ultimately the data collected can be used to train neural network algorithms and the algorithms may then be used to provide diagnostic and/or prognostic information based on the individual test results of any given test subject.

In accordance with another aspect of the present invention in respect to the analysis of blood, the cellular components of a blood sample are separated from plasma by allowing the whole blood to be exposed to microsphere beads which permit the plasma, but not the cellular component, to pass in the spaces formed between the
5 microspheres by capillary action. The present invention is not limited to the separation of cells from plasma in blood but includes broader applications where microsphere beads may be used to separate a fluid component from a cellular component in a biologic fluid. The microsphere beads are effectively acting as a fluid
filter.

10 According to another aspect of the present invention a device is provided for separating plasma from blood in a sample. The device comprises a plurality of microspheres disposed in a transiently abutting relation and forming therebetween a plurality of capillary channels, whereby when the microspheres are disposed in fluid communication with a blood sample cellular and plasma components of the biologic
15 sample are separated by capillary flow of the plasma component through the capillary channels formed by the interstitial spacing between abutting microspheres.

According to another aspect of the present invention the device comprises a plurality of groups of smaller microspheres each impregnated with a different label and interspersed with the larger microspheres in separate zones of the larger
20 microspheres. The microspheres may be of substantially the same diameter, or the microspheres may be of differing diameters. The size of microsphere selected may be based on the viscosity of the sample or the size of the component one wishes to exclude or separate.

In accordance with yet another aspect of the present invention, the microspheres are bundled in a fluid-permeable material or the microspheres are maintained in a transiently abutting relation by a surface tension of the fluid which passes through them, for example plasma. In accordance with yet another aspect of the present invention the microsphere beads, also known simply as microspheres, are dried on a surface of the device.

In accordance with another aspect of the present invention, the device comprises a sample shelf adjacent to the fluid entrance and the microspheres are disposed on the sample shelf. In another embodiment, the device comprises a sample well disposed adjacent to the fluid entrance which is capable of holding the microsphere beads in place, and which also acts to ensure that no sample bypasses the microsphere beads.

According to yet another aspect of the present invention the device comprises a plurality of smaller microspheres which are impregnated with at least one label interspersed with a plurality of larger microspheres such that the smaller microspheres occupy the interstitial spacing between the larger microspheres and release a label into the fluid as it flows through the interstitial spacing between the larger microspheres. There may be a plurality of groups of smaller microspheres each impregnated with a different label and interspersed with the larger microspheres in separate zones of the larger microspheres. Alternatively, the smaller microspheres may be mobilized and carried forward by the fluid as it passes along the capillary channels formed by the larger microspheres.

In accordance with another aspect of the present invention, the device comprises an indicator means containing identification information to be associated

with results of the assay (e.g., patient information), for example a bar code which can be read by a bar code reader.

According to another aspect of the present invention, a method of separating fluid from a biologic sample is provided. The sample has a fluid component and a
5 non-fluid component and the method comprises the steps of,

- (a) bringing the sample into fluid communication with a plurality of microspheres disposed in a transiently abutting relation and forming therebetween a plurality of interstitial spaces which connect to comprise transient capillary channels,
and
- 10 (b) collecting the fluid component as it is separated by capillary flow of the fluid component through the capillary channels.

According to another aspect of the present invention there is provided a method of assaying a fluid sample which utilizes a device comprising a capillary chamber defined by first and second opposed surfaces spaced a capillary distance
15 apart having a fluid entrance and at least one reagent disposed within the capillary chamber, comprising the steps of,

- (a) conveying a fluid sample into fluid communication with the fluid entrance such that the fluid sample is drawn into the capillary chamber by capillary action and reacts with the reagent, and
- 20 (b) analyzing the reagent to determine whether the reagent binds to an analyte in the fluid sample.

According to another aspect of the present invention the method further comprise the step of analyzing the reagent to determine a proportion of the reagent which binds to the sample.

According to another aspect of the present invention, the method further comprises a plurality of capillary chambers for conducting a plurality of assays on one or more fluid samples.

According to another aspect of the present invention the results of the tests are
5 recorded in a computer database and may be further applied in a trained neural network algorithm to generate a profile of one or more selected disorders. The assay further comprises the step of applying a receiver operating characteristic analysis to the data to determine a statistical significance of the data.

In accordance with another aspect of the present invention a wick or a
10 capillary is brought into fluid communication with the fluid sample to remove the fluid sample from the capillary chamber.

In accordance with another aspect of the present invention microspheres are used to separate a cellular component from a fluid component in a biologic fluid, for example plasma from whole blood, and the resulting fluid component can be tested in
15 conventional chromatography test strips. Furthermore, the microsphere beads of the present invention may be used as a labeling device, in addition to a filtration device, in standard nitrocellulose chromatography assays.

In accordance with another aspect of the present invention, microspheres are used to separate and/or concentrate microbial contaminants from a suspension of a
20 sample to detect the presence of and quantify the numbers of microbial contaminants in the sample. Such samples may include, for example, food, water, soil or fecal samples.

In accordance with another aspect of the present invention, a device for assaying a fluid sample comprises a chamber defined by two non-contiguous surfaces

and having at least one fluid entrance. Hereinafter we refer generally to such a device as a "biochip". The non-contiguous surfaces of the biochip are separated by a distance sufficient to create capillary flow of the fluid sample into the chamber through the fluid entrance. The biochip further includes a dynamic capillary filter
5 which is in fluid communication with the fluid entrance and which also includes a plurality of particles. The particles are in a transiently abutting relation with one another and form interstitial spaces therebetween, whereby when the fluid sample contacts the dynamic capillary filter, the fluid sample flows into the dynamic capillary filter, whereupon a fluid component of the fluid sample is separated from a non-fluid
10 component of the fluid sample by passage through the interstitial spaces of the dynamic capillary filter and the fluid component thereafter flows into the chamber through the fluid entrance.

In accordance with another aspect of the present invention, the biochip further includes one or more reagents. An analyzer capable of detecting a reaction between
15 the reagent and at least one analyte that may be present in the fluid sample is provided to constitute an assaying system with the biochip. The biochip includes a chamber defined by two non-contiguous surfaces and having at least one fluid entrance. The non-contiguous surfaces are separated by a distance sufficient to create capillary flow of the fluid sample into the chamber through the fluid entrance. The device further
20 includes a dynamic capillary filter which is in fluid communication with the fluid entrance and which also includes a plurality of particles. The particles are in a transiently abutting relation with one another and form interstitial spaces therebetween, whereby when the fluid sample contacts the dynamic capillary filter, the fluid sample flows into the dynamic capillary filter, whereupon a fluid component

of the fluid sample is separated from a non-fluid component of the fluid sample by passage through the interstitial spaces of the dynamic capillary filter and the fluid component thereafter flows into the chamber through the fluid entrance. One or more reagents can be bound to an interior face of at least one of the non-contiguous
5 surfaces. The reagent is capable of reacting with one or more analytes that may be present in the fluid sample. As set forth above, the assaying system further contains an analyzer capable of detecting a reaction between the reagent and at least one of the one or more analytes that may be present in the fluid sample.

In accordance with another aspect of the present invention, a method for
10 detecting or measuring the amount of a component of a fluid sample comprises the steps of:

a) providing an assay device that includes a biochip, which includes a chamber defined by two non-contiguous surfaces and having at least one fluid entrance. The non-contiguous surfaces are separated by a distance sufficient
15 to create capillary flow of the fluid sample into the chamber through the fluid entrance. The device further includes a dynamic capillary filter which is in fluid communication with the fluid entrance and which also includes a plurality of particles. The particles are in a transiently abutting relation with one another and form interstitial spaces therebetween, whereby when the fluid
20 sample contacts the dynamic capillary filter, the fluid sample flows into the dynamic capillary filter, whereupon a fluid component of the fluid sample is separated from a non-fluid component of the fluid sample by passage through the interstitial spaces of the dynamic capillary filter and the fluid component thereafter flows into the chamber through the fluid entrance. The biochip may

further include one or more reagents bound to an interior face of at least one of the non-contiguous surfaces. The reagent is capable of reacting with one or more analytes that may be present in the fluid sample. The assay device further contains the analyzer capable of detecting a reaction between the reagent and at least one of the one or more analytes that may be present in the fluid sample;

- b) applying the fluid sample to the assay device under conditions under which the fluid sample passes through the dynamic capillary filter and thereafter into the chamber through the fluid entrance;
- 10 c) detecting a presence of a reaction product formed as a result of a reaction between the reagent and one or more analytes that may be present in the fluid sample; and
- d) optionally, measuring at least one of an amount of and a concentration of the reaction products.

15 In another aspect of the present invention, there is provided a method for assessing pre-and post symptomatic health conditions of a patient, comprising the steps of:

- a) obtaining a bodily sample from the patient;
- b) analyzing the bodily sample for the presence, absence, and optionally a concentration or amount of an analyte;
- 20 c) repeating steps a) and b) a desired number of times, the desired number being at least once, to create a data pool for the patient;
- d) constructing a database, based on the patient's medical history, current health and the data pool;

e) inputting numerical values from the database into a neural network algorithm, the neural network algorithm being optimized to predict a health outcome from the numerical values; and

f) producing a predicted health outcome from the step of inputting numerical values into the neural network algorithm.

In all aspects of the present invention described herein which use uniform microspheres of defined shape and size, the microspheres could be replaced by non-uniform particles of differing sizes and/or shapes as described further below. For example silica sand could be used to replace the polystyrene microsphere beads.

Other suitable particles would be known to a person skilled in the art having the benefit of the present description.

Other and further details of this preferred embodiments are described in the Detailed Description of the Preferred Embodiments together with the drawings described below.

15

Brief Description of the Drawings

For the purpose of illustrating the invention, there is shown in the drawings a form which is presently preferred. It is not intended that this invention be limited to the precise arrangements and instrumentalities shown. The present invention will be described in detail with reference to the accompanying drawings, in which like numerals denote like parts in the several views, and in which:

Figure 1 is an schematic, exploded, perspective view of an embodiment of the device of the present invention.

Figure 2 is a longitudinal cross section of the preferred embodiment illustrated in Figure 1 along line 1A - 1A.

Figure 2A is an end elevation view of the device illustrated in Figure 2 taken from the perspective of line 2A - 2A.

5 Figure 3 is a side view of an embodiment described in Example 1 illustrating the cover slip in relation to the beads when starting to form the curl.

Figure 4 is also a side view of an embodiment described in Example 1 illustrating the curl after formation;

10 Figure 5 is another side view of an embodiment described in Example 1 illustrating the position of the cover slip in relationship to the beads on the microscope slide.

Figure 6 is a top plan view of an embodiment described in Example 1.

Figure 7 is a side view of an embodiment described in Example 2 illustrating the label pad variant.

15 Figure 7A is a side view of another embodiment described in Example 2 illustrating the replacement of the label pad with microsphere beads.

Figure 8 illustrates an example ROC curve for the expected test results for a neural network risk analysis test.

20 Figure 9 is a photomicrograph taken at 400x magnification using a light powered microscope showing the appearance of unseparated yogurt as applied to the shelf of the biochip.

Figure 10 is a photomicrograph taken at 400x magnification using a light powered microscope showing a fluid portion of the yogurt seen in Figure 9 after separation using microsphere beads having a 15 μm diameter.

Figure 11 is a photomicrograph taken at 400x magnification using a light powered microscope showing a fluid portion of the yogurt seen in Figure 9 after separation using microsphere beads having a 10 μm diameter.

5 Figure 12 is a photomicrograph taken at 400x magnification using a light powered microscope showing the appearance of unseparated *E.coli* and bread suspension as applied to the shelf of the biochip.

Figure 13 is a photomicrograph taken at 400x magnification using a light powered microscope showing a fluid portion of the *E.coli*/bread suspension seen in Figure 12 after separation using microsphere beads having a 15 μm diameter.

10 Figure 14 is a photomicrograph taken at 400x magnification using a light powered microscope showing the appearance of unseparated cow feces as applied to the shelf of the biochip.

Figure 15 is a photomicrograph taken at 400x magnification using a light powered microscope showing a fluid portion of the cow feces seen in Figure 14 after separation using microsphere beads having 15 micrometer diameters.

Figure 16 is a photomicrograph taken at 400x magnification using a light powered microscope showing a fluid portion of the cow feces seen in Figure 14 after separation using microsphere beads having a 10 μm diameter.

20 Figure 17 is a photomicrograph taken using a light powered microscope showing silica sand as applied to the shelf of the biochip and showing a 1 mm scale illustrating the size of the silica sand grains.

Figure 18 is a photomicrograph taken at 400x magnification using a light powered microscope showing a fluid portion of the *E.coli*/bread suspension seen in Figure 12 after separation using silica sand grains.

Figure 19 is a photomicrograph taken at 400x magnification using a light powered microscope showing a fluid portion of the cow feces suspension seen in Figure 14 after separation using silica sand grains.

Figure 20A is a perspective view of the top portion of another embodiment of the device of the present invention, showing a well in which the microsphere beads may be placed.

Figure 20B is a perspective view of the bottom portion of another embodiment of the device of the present invention, showing tracks in which a cap may be slidably placed.

Figure 21 is a perspective view of a cap that fits slidably over the device of Figure 20 to hold the beads in place.

Detailed Description of the Preferred Embodiments

The present invention relates to a method of separating a fluid component from a biologic sample using microsphere beads or other suitable particles. The present invention further relates to a device and a method for analyzing the presence or absence of an analyte in a biologic fluid sample. The invention also relates in one aspect to quantifying with precision the amount of one or more analytes present in a biologic fluid sample. The present invention can also provide quantitative as well as qualitative results. The present invention further relates to a method for interpreting test results obtained by the methods of the present invention and can be used to further identify certain medical conditions from which a person or animal may be suffering or is likely to suffer from in the future. The present invention further relates to a prognostic assay technique in which the results of the test assay defined in the present

invention may be used to predict the likelihood of a person or animal developing a certain condition or disease state at a future time. These various embodiments are described in detail herein.

Although the preferred embodiments described herein are described with respect to the testing of human biologic samples it is well understood that such assays and methodologies could equally be used for assessing biologic samples in other animals. In particular the present invention would clearly have applicability to veterinary services and in research laboratories. Furthermore, the term fluid sample as used in this specification, is intended to be interpreted broadly to include suspensions and other samples that have a fluid portion which can be separated by fluid flow and/or capillary action. For example, suspensions of food, water, soil, or fecal matter could be tested for the presence of microbial, i.e., viral, bacterial, or fungal, contaminants.

In a biologic fluid sample having a fluid component and a non-fluid component, the fluid component containing an analyte of interest the present invention may be used to measure any of the following, alone or in combination:

- a) the presence of the analyte in the sample;
- b) the absence of the analyte in the sample;
- c) concentration of the analyte in the sample; or
- d) total amount of analyte in the sample.

Suitable analytes which may be measured by the assay and device of the present invention include soluble analytes; i.e., enzymes, proteins, bacteria, fungi, viruses, antigens, antibodies, immunoglobulins, drugs, and hormones. Other suitable analytes would be known to one skilled in the art. The assay and device of the present

invention are also useful for the detection and measurement of drugs of abuse in human biologic samples, such as performance enhancing drugs or street drugs.

Some biologic samples can be assayed without first separating out cellular components; however, in many cases, it is necessary to first separate the fluid component from any cellular components. For example, in the case of blood, the cellular component can interfere with the assay. Therefore, the plasma must be separated from the cellular components so that the cellular components of the blood do not interfere with the testing for the analyte which is present in the plasma.

It is recognized in the present invention that, surprisingly, the fluid component of a biologic sample can be separated from its non-fluid component by applying the sample to a group of particles, such as microsphere beads. When the sample is applied the fluid component flows in between the particles as they move, forming transient channels or pores. In this manner, the fluid components of the sample are separated from the cellular components in a simple and effective way. The beads act as a means of separating the fluid component from the non-fluid component as the fluid component moves by capillary action, through the spaces transiently formed between the particles. So, in the case of blood, plasma is separated from the cells, such as leukocytes, erythrocytes and platelets, in the blood sample, quickly and efficiently.

In a preferred embodiment, the particles are latex microsphere or polystyrene beads, such as those sold under the trademark Bang's™. The beads are supplied in a liquid suspension. The beads can either be kept moist or dried when used. Other types of particles could be used in the invention, including glass, so long as the

particles are effective to separate the fluid components of the sample from the non-fluid components.

For the purposes of this patent application the spaces between the beads are called "interstitial spaces" or "pores". It is believed that the fluid flows by capillary
5 action from one interstitial space to the next. The microsphere beads act as a fluid filter and as such can be used at any point in an assay where simple fluid filtration, separation or partitioning, is required. Since it is believed that the microspheres act to filter, separate or partition the fluid component from the non-fluid component by
10 capillary action, the microsphere filter may be termed a dynamic capillary filter and this term is used for that purpose herein. The capillary filter is a dynamic filter in the sense that the beads are seen, under a microscope, to move randomly and without an overall direction of movement during the partitioning of the fluid component. At any one point in time, some beads move and others remain still but overall random but directionless movement of the beads is observed microscopically. It is expected that
15 with the movement of the beads at any one time some capillary channels will be closed and others will be open. In this sense, the capillary channels may be transient. The interstitial spaces between the beads or particles, as well as the contact between the beads, are also expected to show the same transience with respect to movement of the beads or particles during fluid partitioning.

20 The flow of the fluid passing through the interstitial spaces between the beads is likened to flowing along channels formed by the spaces between the beads. The channels are referred to as "capillary" channels because it appears that the fluid flows between the beads by "capillary" action.

The size of the space formed between the microspheres is a function of the radius of curvature of the microspheres. The radius of curvature is, for the purposes of the present invention, the same as the diameter of the microsphere. To understand the relationship between the microsphere bead size and the pore size which is formed
5 between the beads, it is known that the ratio of the microsphere diameter to pore diameter is approximately 1 to 0.4. In the case of separating out the plasma from whole blood, a pore size of 4 μm is considered optimal. Therefore, the bead size for this particular embodiment is 10 μm . This permits an easy fluid flow (and therefore faster fluid flow) while still preventing cells from passing through the pores. The
10 small spaces formed between the beads provide a certain capillary force when a fluid is present. When the detection of bacterial contaminants of a sample is desired, the optimal bead size is 15 μm , due to the larger size of the bacterial cell. This provides pore sizes of 6 μm .

It has also been found, surprisingly, that particles of non-uniform size and
15 shape also work, in accordance with the principles of the invention as taught herein. Specific examples of non-uniform particles are described in Example 7 below. It is understood that the following description with respect to microsphere beads teaches the principles which are also applicable to the use of other similar separation particles such as silica and other equivalents.

20 In the present invention the use of microsphere beads is an effective and inexpensive means for separating plasma from whole blood, as the erythrocytes and leukocytes in the blood will stay on the side of the beads where the sample is applied, while the plasma portion of the blood sample will pass through the beads, by capillary-like action along the interstitial spaces or pores formed between the beads.

It is considered that the capillary action observed in the present invention is related to the surface tension exerted by the microspheres on the fluid so as to draw the fluid in a direction away from the beads.

As the fluid is drawn between the microspheres it provides the additional
5 advantage of mobilizing any reagents present in the region of the microspheres. For example, the microsphere layer could be impregnated with secondary antibodies or another detection molecule. The microspheres alternately may contain analyte-specific antibodies bound to them, for example, by adsorption or coupling. As the fluid containing the plasma passes through the capillary channels formed by the
10 microspheres the analyte will mobilize the secondary antibodies contained on the microspheres and then react with the primary antibodies contained in the biochip. However, the microspheres may act solely to separate the cellular component from the fluid component and the microspheres need not be labeled with antibodies.

Prior art technology has used chromatographic paper or other fibrous material
15 to wick the fluid component of a biologic sample away from the cellular component in order to perform tests on the fluid portion without interference from the cells or other substances present in the sample. The microspheres of the present invention provide an advantage over the prior art technology because it provides improved fluid flow without restriction by the fiber which is present in the chromatographic paper. The
20 microspheres provide a further advantage in that they provide an excellent surface for binding of proteins such as antibodies or other suitable labels.

The size of the microsphere beads used to separate the fluid component can be varied based on the viscosity of the sample. Larger beads may be used for more viscous samples for faster fluid flow between the beads. The beads may be of a size

up to 5,000 μm in diameter. Preferably, the beads are of a size up to 50 μm in diameter. More preferably, the beads are in a range between 5 and 15 μm in diameter. Also, beads of different colours may be used to facilitate visualization of the beads when they are used as labels and bind to the analyte. The bound beads also serve to
5 increase the density of any bound analyte for subsequent detection by a spectrometer. The regular pattern of the beads also means that light absorption differences could be used for detecting and measuring bound analyte.

The use of microsphere beads to quickly separate out a fluid component from a biologic sample can be incorporated into assays for detecting and quantifying
10 analytes present in the sample. According to one aspect of the present invention this method of separating out a fluid sample from a biologic sample using microsphere beads is incorporated into a one-step assay for analyzing one or more analytes which may be present in the fluid sample. The assay is performed in association with a chamber of defined volume. In a preferred embodiment the chamber is associated
15 with microsphere beads for separating out the fluid sample and detection means for detecting and/or measuring an analyte in the sample. The detection means may be drawn from any of several known methods for detecting an analyte in a sample. For example, the analyte may be recognized using a detection protein, such as an antibody or antigen, which is specific to the analyte. The detection protein may bind to the
20 analyte and itself be detected in any of a number of ways known to those of skill in the art. For example, the detection protein may be an analyte-binding protein that is linked to an enzyme that produces a colored reaction product upon incubation with an appropriate substrate, as is normally done in ELISA-type assays. Alternatively, the detection protein may be bound to another label, which can be detected. Suitable

labels include metals such as gold, fluorescent labels, chemical labels, or colorimetric labels.

The present invention also pertains to point-of-care diagnostic or prognostic tests, which may include a small chip or cassette for use in assaying biologic samples such as blood. The chip or cassette can be referred to as a biochip, as that termed is broadly defined above. The biochip is created by a pairing together of two carrier surfaces in order to define a specific volume in which a quantitative measurement of analyte(s) present in a sample may be measured. In a preferred embodiment the surfaces in question are a coverslip and a microscope slide but the present invention is not intended to be limited to only these specific embodiments. An important aspect of the present invention is the fact that a fluid sample enters a space of defined volume by capillary action. The defined space is therefore referred to herein as a capillary chamber. In the case of a microscope slide and coverslip the capillary chamber is that volume of space between the bottom of the cover slip and the top of the slide.

The amount of fluid which is present between the plates or slides is determined by the volume of space between the slides. Plates of larger surface areas would require greater sample volumes, and, conversely, plates of smaller surface areas require smaller sample volumes. Test systems can be designed which allow for precision testing of very small volumes, in some cases, as small as a few microliters. This facilitates assays of samples having very small volumes, i.e., a droplet of blood from a pinprick. The distance between the two plates is limited only by the ability of the plates to effectively draw a fluid such as plasma between the two plates by capillary action and to retain the fluid in the defined volume. The size of the plates

used would also be dictated by practical considerations such as the desired volume for testing.

The small sample size required for the present invention also would be useful in medical research that employs experimental animals, such as rodents. By
5 employing smaller bodily samples from each individual animal, it is possible to take multiple samples from the animal over short periods of time. In this fashion, fewer animals may be needed for each experiment, since in place of multiple animals to follow the results of a particular treatment, multiple samples may be taken from the same animal at different times.

10 In order to quantitatively measure the concentration of an analyte in a sample and to compare test results from one test to another it is advantageous to have a consistent test volume of the fluid sample each time the assay is performed. In this way the analyte measurement is assessed directly without having to adjust for varying volumes. The concentration or quantity of analyte can be assessed directly without
15 difficulty and with consistency from test to test. The chamber of the biochip of the present invention provides that defined volume. The chamber may also have a standardized volume for comparing the results of the assay to those obtained in other assays.

20 Once in the capillary chamber, the fluid sample is retained by way of surface tension at the ends and edges of the two surfaces. In another embodiment the plates are joined together such that the fluid sample may be readily removed, i.e., at the end opposite the point of fluid entry. In this regard, the sample may be removed by contacting the sample with a wicking at the end of the chamber opposite the point of fluid entry to withdraw the sample in the chamber. The wick may be a bibulous

material or any material capable of withdrawing the sample via capillary action, mass action transfer, or the like. In this fashion, the entire fluid component of the sample may be passed through the chamber.

The biochip is of a small size which makes it easily portable. The biochip can
5 be inserted into an analyzer and reaction products between the analyte and detection molecules then can be measured using the analyzer. The biochip may be adapted for use in a vertical orientation if a means is adopted to hold the microspheres in place. For example, a Nylon™ mesh or the like may be used to hold the beads, or the beads may be trapped in a fluid permeable matrix affixed to the biochip. For the purposes of
10 describing certain preferred embodiments the carrier surfaces will be referred to as plates; however, the invention is not to be limited only to flat plates. Similarly, all types of surfaces which are able to bind proteins, antigens and other detection molecules are contemplated as being within the scope of the present invention. Specifically the composition of the carrier surface of the biochip may include, but is
15 not limited to, glass, plastic and metal. It should be noted that the carrier surface should not be comprised of a material which interferes with analyte detection. In a preferred embodiment, the carrier surface is made of a plastic, such as polystyrene, which can be manufactured at a minimal cost, making it ideal for single-use applications.

20 In a preferred embodiment of the present invention a drop of a biologic sample, such as blood, a blood product, urine, saliva, semen, and the like, is placed on the top surface of the microscope slide and, before entering the capillary chamber, the cellular component of the sample is removed by movement of the fluid component through a group of microsphere beads. For example, in the case of blood, the plasma

is separated from the cellular components of blood by movement of the fluid component of the sample through capillary channels in interstitial spaces between the beads. Then the fluid enters the testing chamber in which the analyte reacts with reagents in the chamber and the reaction product is a measure of the analyte present in
5 the sample.

Once the fluid has entered the defined space it may be exposed to one or more reagents present on an interior face of a carrier surface. The reagents are exposed in the capillary chamber and available for reacting with one or more analytes which may be present in the fluid sample which ultimately fills the capillary chamber. The
10 reagents are labelled and the quantity of analyte present in a fluid sample is measured based on a reaction product which results from the interaction of the analyte in the sample with the reagent in the chamber. The test results are then compared to standard calibrations to determine the quantity of analyte present in the sample.

In a preferred embodiment of the present invention the reagent is one or more
15 analyte specific antibodies which are adhered to the carrier surface. Alternatively, in another embodiment, an antigen is present on an interior face of the carrier surface and the amount of antigen specific antibody in the sample is measured. When bound to the carrier surface the protein or other detection molecule will project into the defined space where it can react with the analyte in the sample. The detection
20 molecule which is present on the interior face of the carrier surface may be bound to the surface by any one of several means known to a person skilled in the art.

Detection molecules are either coated, printed or otherwise bound to one plate or the other using one of several techniques well known in the art. Numerous techniques for immunoassays are known to persons in the art and are described, for

example, in "Principles and Practise of Immunology" (1997), C.P. Price and D.J. Newman eds. (Stockton Press) and this document is hereby incorporated by reference into the instant patent application and made a part hereof as if set out in full herein.

Analyte-specific antibodies themselves may be labeled with any one of several
5 labels known to persons skilled in the art of such assays. Examples of preferred labels include fluorescent labels, colorimetric labels, another microsphere, gold particles or any high contrast molecule. Other labels would be suitable so long as the presence of the label can be detected. Similarly microsphere beads having a diameter which is smaller than the test beads can be used so that the smaller beads are mobilized through
10 the larger beads with the movement of the fluid sample (e.g. plasma). The smaller beads can be labeled accordingly.

When the fluid sample containing the analyte enters into the defined space between the two plates a further antibody-antigen reaction may occur. In a preferred embodiment of the present invention the upper plate, for example a coverslip, has
15 analyte-specific reagents bound on the surface which comes in contact with the fluid. The analyte-specific reagents may be printed on the interior surface of the plate using a protein printer. Suitable protein printing devices are well known in the marketplace. These include ink jet, spray, piezo-electric and bubble jet protein printers. The piezo-electric printer is preferred. Such a printer is available from Biodot (Irvine, CA). The
20 analyte-specific reagent acts as a detection molecule, typically proteins. These molecules adhere to glass, metal and plastic surfaces. Preferred surfaces include polystyrene or polypropylene. The use of such printing devices is advantageous in the present invention to allow several different analyte-specific detection molecules to be printed onto the plate or coverslip such that different "lanes" are defined and different

analytes may be assessed simultaneously using a single fluid sample. Additional background and calibration lanes can be provided in the same test chamber.

After the analyte reacts with the analyte-specific detection molecule a measurable reaction product will be produced. It is preferred that the biochip carrier surfaces be colorless or transparent such that a colorimetric, or fluorescent or other reaction products can be read using a suitable spectrometer or other appropriate detection coupled to a reader. When the analyte and analyte-specific detection molecule react together there is a change in the intensity of the reaction product in the reaction lane. In a preferred embodiment of the present invention, the change in intensity is measured to determine the amount of analyte present in the sample. In order to reduce the background noise and therefore increase the sensitivity of the assay a mask may be provided. Referring to Figure 1, the mask 32 is made of an opaque material except for the openings 36, 38 and 40 which correspond to lanes 26, 28 and 30 on the plate. The mask is designed to fit neatly over the upper plate 10 so that only the lanes themselves are available to be read. The use of the mask has the advantage of reducing the amount of background noise and setting baseline values when reading the density change in the lanes.

In another example, the space between the two plates could be divided into lanes and the volume of each lane would similarly be known. This approach would allow multiple tests to be done on a single sample.

In the present invention it is desirable that the test results be made available in a short time frame, preferably on the order of 1 to 30 minutes, from beginning to end. An advantage of the present invention is that the fluid sample enters the test chamber in a shorter time than prior art assays, since the use of microsphere beads to separate

the plasma from the blood sample eliminates the delay which would occur using fiberglass or chromatographic strips. Cumbersome equipment such as a centrifuge is not required for cell separation. The increased speed and simplicity of the present invention facilitates the test being performed at the point-of-care.

5 The present invention has further advantages over the prior art since the biochip device of the present invention permits several assays to be performed on one sample. This facilitates the speed with which test results can be obtained and minimizes the amount of sample required for testing.

 In a preferred aspect of the present invention, the biochip is designed to be
10 read by a portable spectrometer which reads for example, the change in color after the analyte has reacted with the labeled antibody. The spectrometer could also read changes in density, film thickness, mass absorption or diffraction depending on the test reagents used. In a preferred embodiment, the spectrometer is a DNAscope (Biomedical Photometrics, Inc., Waterloo, Ontario, Canada). Once the analyzer, e.g.
15 the spectrometer, has performed the necessary data calculations the results are transmissible by digital transmission over the telephone lines, by cell phone, or other computer network system. Alternatively, changes occurring during an antibody/analyte reaction may be detected or measured by changes in radio frequency if a radio frequency sensor is incorporated into the biochip detection system.
20 Alternatively, changes in the concentration of a fluorescent reaction product may be detected using a fluorimeter.

 Data obtained by the methods and devices of the present invention may be accumulated in one or more databases to provide a resource for diagnosis and prognosis. For example, data obtained from a large number of patients afflicted with

a disease or condition that is associated with a change in a measurable parameter, i.e., concentration of a metabolite or enzyme in the blood, can be pooled and compared to the values obtained for the same parameter in unafflicted patients. Then, a patient suspected to be suffering from the same disease or condition can be diagnosed based
5 on the values obtained for the parameter. The devices and methods of the present invention are advantageous in that they are amenable to point-of-care diagnosis, and further the small sample sizes required for the assays permit multiple and ongoing determinations of the values for the parameters. Therefore, the efficacy of treatment regimens can be followed on a small time scale, so that the delay between treatment
10 and parameter measurement is minimized.

Alternatively, because the present invention enables multiple point-of-care measurements, a database may be created for each individual patient, based on the numerous measurements taken over a relatively short period of time. In this manner, the progress of the patient can be monitored virtually continuously, and compared to
15 his or her condition at earlier time points to assess improvement or deterioration in the patient's condition.

In addition, the data obtained for multiple patients can be used to track the initiation and development of disease conditions. Measurements taken of multiple parameters in a large population can be assessed to detect correlations between
20 changes in measurable parameters and the development of a disease. Once such correlations are detected, an individual can be measured for changes in the parameter that are prognostic of the development of the disease.

Turning to the figures, Figure 1, a preferred embodiment of the biochip of the present application is illustrated in a schematic exploded perspective view. Two

carrier plates 10 and 12 are provided. The two plates define a fixed volume therebetween that creates a chamber 14. Lower plate 12 may be longer than upper plate 10 to provide a shelf which acts as an application zone 16 upon which a biologic sample 18 may be applied. A shelf is not essential to the invention but provides a place to allow the sample to be separated by the microsphere beads.

Also affixed to application zone 16 is a collection of microsphere beads 20 which may or may not also include a label zone 22. The microsphere beads 20 may be grouped or bundled using a fluid-permeable material. For purposes of the schematic illustration, in Figures 1 and 2, microsphere beads 20 and label zone 22 are illustrated as separately defined regions; however microsphere beads 20 may also bear the label themselves and in this embodiment the two zones would converge into one with the microsphere beads playing two roles: separation of the fluid and displaying a label to which the fluid is exposed. It is possible that the beads could be placed at the entrance of capillary chamber 14 within the confines of the plates and the sample would be applied to the edge of the biochip where it would enter the chamber by capillary action. Furthermore, although label zone 22 is shown as preceding microsphere zone 20, label zone 22 could also follow microsphere zone 20, or multiple label zones 22 could be placed before and after microsphere zone 20, as desired.

Alternately, as shown in Figure 20A, microsphere beads 20 (not shown) may be held in a well 71 having an outlet 72 in fluid communication with chamber 14 on a surface 73. Well 71 holds microsphere beads 20 in place, and outlet 72 has an opening that is smaller than the diameter of microsphere beads 20. Outlet 72 can be fabricated by i.e., use of a laser to have an opening less than the diameter of

microsphere beads 20. In this embodiment, fluid sample 18 (not shown) is applied to well 71 containing microsphere beads 20, and must first pass through microsphere beads 20 before entering outlet 72. In this manner, none of fluid sample 18 can enter chamber 14 before passing through microsphere beads 20. This embodiment has the advantage of greater sample treatment reliability.

Alternately, outlet 72 may be greater than the diameter of microsphere beads 20 if steps are taken to block passage of microsphere beads 20 through outlet 72 into chamber 14. For example, outlet 72 may be in the shape of one or more holes, and a ball placed in outlet 72 could block passage of microsphere beads 20 through each hole of outlet 72 if the difference in diameter between the ball and outlet 72 is less than the diameter of microsphere beads 20. Alternately, outlet 72 may be in the shape of a channel, and a rod having a length substantially equal to that of the channel could be used to block passage of microsphere beads 20 through outlet 72, so long as the difference in diameter between the rod and outlet 72 is less than the diameter of microsphere beads 20. In this case, by "substantially equal", it is meant that the length of the rod is such that none of microsphere beads 20 can pass through the channel to outlet 72 at the ends of the rods. In general, outlet 72 may be of any shape so long as there is a matching element that can be inserted into outlet 72 and block passage of microsphere beads 20 into chamber 14 through outlet 72.

More than one size of microsphere beads may be present. In one embodiment, smaller microspheres could nestle in the interstitial spaces formed by the larger beads. The smaller beads could carry secondary labels which would bind to the analyte as it passes through the beads. Either the label would bind to the analyte in the fluid or the label attached to the small bead would attach to the analyte in the fluid and the small

beads would then travel with the fluid into the capillary chamber. At the same time any cellular component in the fluid sample would not pass through the microsphere bead filter.

A sample ID may be affixed to either plate 10 or 12 so long as it does not
5 interfere with the test detection areas on the biochip or with reading the biochip after analyte has reacted with the substance bound to the carrier plate surface. In a preferred embodiment, the sample ID is in the form of a barcode. The plates 10 and 12 are preferably colorless and/or transparent.

Three detection areas 26, 28, 30 are printed on the inner surface of carrier plate
10 10: a calibration print zone 26, a detector print zone 28 and a baseline print zone 30. Three detection areas, or zones, are depicted for example only to illustrate how one test biochip may be set up; however, several lanes may be present and the number of lanes dedicated to calibration and/or background can vary depending on what is being tested.

15 The test need not be limited to only three lanes. Several lanes could be defined. In a preferred embodiment of the present invention three lanes are printed on the one plate to permit assessment of background readings as well as calibration of the biochip. It is understood that the background and calibration detection zones need not all be placed on the same biochip. It is advantageous to have the background and
20 calibration readings made on the sample carrier plate in the same assay as the test analyte thereby reducing the variance in test results.

A background mask 32 is optionally provided. The mask is designed to cover the outer surface of the carrier plate 10 without blocking the coated or printed detection zones/lanes. Therefore, openings 36, 38 and 40 are, for example, present in

the mark to reduce background interference when reading test results. The background mask is made of an opaque material with openings 36, 38 and 40 which correspond to the detection zones 26, 28 and 30 identified on the inner surface of the upper plate. The opening 40 in the mask need not have a corresponding test zone 30 as illustrated so long as the opening 40 is exposed to a part the plate 10 where reagents are not present.

Although Figure 1 illustrates both an antibody/label zone 22 and a microsphere zone 20, both of these zones are optional depending on the type of test one chooses to conduct. When fluid sample 18 is applied to application zone 16 it flows through antibody/label zone 22 (if present) and microsphere bead zone 20 (if present) before it reaches edge 34 where the two plates 10 and 12 first meet. In the schematic illustration of Figure 1 there is a gap between the zone of microsphere beads and the fluid entry point identified by edge 34. Although this arrangement of the invention will work, it would be most preferred if the microsphere bead zone 20 and/or label zone abutted against edge 34 of carrier plate 10. One example of such a configuration is illustrated in Figures 5 and 6. This configuration provides the least distance for the fluid sample to travel and this further minimizes the amount of fluid sample required for testing and is described in greater detail in Example 1.

The fluid sample is drawn under edge 34 into chamber 14 which defines a known volume. The fluid sample should be of sufficient volume to pass along application zone 16, through the microsphere and label zone(s) and to completely fill chamber 14. The biochip of the present invention can be scaled to a small size such that a single drop of blood could be a sufficient sample size for testing. Many dimensions are possible to construct based on the principles taught herein. Although

dimensions of 1 cm x 3 cm make a device of convenient size, the nature of the testing to be done would dictate the optimum chip size. As illustrated in Figure 1 a shelf portion 16 extends on the bottom plate. On this shelf portion the biologic sample can be applied. In other embodiments, the portion of the test which is held, for example the microscope slide, may be large but the test assay itself which sits on the slide may be very small. The assay may be miniaturized to accommodate sample fluid volumes as small as about 1 microliter.

Figure 2 is a sectional view taken along lines 2 - 2 illustrating the same elements as referenced in Figure 1. Figure 2A is an end elevation view of Figure 2 along lines 2A - 2A illustrating that the end of the device may be open, to allow the fluid to be removed from the chamber. One would want to remove fluid from the chamber, for example, if you wanted to test the whole sample. A suitable wicking material would be applied to the open end and the fluid would be drawn through thereby allowing additional fluid to enter the chamber. This could be either a continuous or a discontinuous process.

Illustrated in all of Figures 1, 2 and 2A is a spot of glue 58 which is one way to hold plates 10 and 12 together. The glue 58 also illustrated in Figure 6, another embodiment of the invention. Other methods to hold plates 10 and 12 together would be obvious to one of skill in the art. For example, plates 10 and 12 could be fabricated such that they snap together, and are held in place by frictional forces.

Figures 7 and 7A are illustrations of another use of the microsphere method of separation in a one-step assay. In this embodiment the microspheres are used in conjunction with chromatography paper. The biologic sample 18 is placed on a surface such as a microscope slide 52'. It may be placed directly on the microsphere

beads 50 (as illustrated) or beside them. The fluid component of the sample then flows through the beads 50 separating from a non-fluid component present in the sample 18. The beads abut against or sit close to a fiberglass filter pad 60 which abuts with a label pad 62. The label pad 62 is usually a fiberglass pad impregnated with the label of interest for labeling analyte in the fluid sample. The fluid flows through the filter 60 and label pad 62. Any analyte present in the fluid will be labeled as it flows through the label pad. The fluid then flows into the nitrocellulose chromatography strip 64 where the test results are read, usually as a color change or band on the nitrocellulose strip. Alternatively, since the microspheres 50 are used as a filter, the fiberglass filter 62 may be eliminated entirely (not illustrated).

Finally, as illustrated in Figure 7A, the fiberglass label pad 62 may be replaced by microsphere beads 66. In this case the beads 66 are acting as a source of label, not as a filter and the fiberglass filter 60' serves as a spacer between the two sets of beads 50 and 66, respectively. For applications where filtration of a fluid component is not required, the microspheres 66 can be used to label an analyte present in the fluid directly, without requiring the microsphere filter 50 or the fiberglass spacer 60'.

Figures 7 and 7A are illustrative of how current assay methodologies may be modified using the microsphere bead technology of the present invention as taught herein.

The biochip may also include a cap 75, shown in Fig. 21 in an inverted format, that is adapted to slide back and forth in a lengthwise direction on lower plate 12. Cap 75 snaps onto lower plate 12 and is slidably held in place on lower plate 12 by tabs 76 which run in tracks 74 of lower plate 12 (Fig. 20B). Cap 75 covers well 71 and protects beads 20 (not shown) after they are added to well 71. This protects beads 20

during transportation and storage of the biochip. When the biochip is ready for use, cap 75 is pushed in a direction toward chamber 14, exposing beads 20 for application of sample 18. After sample 18 has passed into chamber 14, the cap is pushed back over well 71, exposing chamber 14 for data collection. Lower plate 12 may optionally
5 contain stops (not shown) to halt the motion of cap 75 along tracks 74, or tracks 74 may be of a defined length.

The assay device and techniques of the present invention are very useful in that they can be used for small volumes of many kinds of fluid samples. Although the description refers specifically to proteins, any number of other markers would be
10 suitable so long as a labeling system can be devised for the detection and measurement of the marker in the system. For example, the present invention could be used to measure and/or detect the presence of microorganisms such as bacteria, viruses, fungi or other infectious organisms. The biochip device of the present invention can be calibrated for the type of assay and the type of analyte so that a table
15 of standard values may be constructed. The assay system or the present invention can detect the levels of a particular hormone or the amount of a drug in a patient's system and this standardized data can be used to make diagnostic and/or prognostic determinations for a given individual.

The ease of use and simplicity of the device of the present invention, coupled
20 with the minimal sample size needed for each reading, means that many multiple tests can be performed on the same patient over a relatively brief period of time. In contrast to conventional testing methods, in which a single large sample of blood is obtained at relatively large time intervals to be aliquoted for multiple tests, the methods of the present invention facilitate sampling far more frequently. As a result,

much more data can be obtained for each patient, and the changes over time of a particular analyte can be more precisely followed. Moreover, since the device of the present invention lends itself well to point-of-care applications, measurements can be taken earlier in time, including measurements that can serve as baseline values. As a result, large amounts of data can be obtained for each individual patient, and this data can be stored in a database. The stored data can be manipulated to spot trends and changes in the concentrations of analytes in a particular patient. Alternately, the data from multiple patients may be pooled, and manipulated as desired to spot trends or changes in particular populations of patients.

10 In another embodiment, the above-identified method can be used to prepare a prognostic test, based on data accumulated from a large number of users. Over time, the changes in a parameter associated with development of a disease can be followed to determine at what point the disease manifests, in a large number of patients. This information can be used to create a predictive database, wherein the course of the disease may be predicted as a function of the change in the parameter in an individual patient.

Tables of standard values can be constructed, based on the known values of the parameters in the target patient group. Once the table of standard values is constructed, data is collected from a patient on a regular basis and patient-specific databases constructed based on the patient's medical history, current health and the test results. Optionally, the data can be transmitted by digital transmission systems over a computer network via modem, the internet, cellular phone systems, cable lines, telephone lines, fiberoptic lines, satellite systems or other similar technology. These databases can be used in the development of neural network algorithms, for

assessment of current patient test results and diagnoses as well as for predicting certain health outcomes for a given individual. One example of a neural network algorithm is found in Example 3 below and a sample Receiver Operator Curve (ROC) is illustrated in Figure 8.

5 The development of the algorithms for the applied neural network will be a function of the medical condition being assessed. Large amounts of patient data will first have to be accumulated in order to have reliable predictive outcomes. The neural network can be trained to recognize the concentration of analyte which is diagnostic or prognostic, using the standardized assays of the present invention. The data and
10 algorithms are encoded in an electronic chip which is placed in the reader, for example a spectrometer, such that the printout from the reader will also identify a particular diagnosis or prognosis simultaneously with providing the test result. In the neural network algorithms, the diagnostic or prognostic test result will be optimized as the number of data points increases. With more patient data the predictive and/or
15 diagnostic result will be made with greater certainty. The percent certainty can be calculated and provided to the physician or technician based on analysis of the measured data in comparison to a database contained in an electronic memory chip installed in the analyzer provided. Present technology makes it possible to display the actual standard curve on the reader itself at the time of printing out the test results.

20 In addition to the use of a spectrophotometer, and in accordance with another aspect of the invention, the biochip may have a radiofrequency sensor incorporated into carrier plate 10. When a reaction takes place in one or more detection areas a measurable change in radio frequency occurs and by detecting this change in radio

frequency the presence or the absence or even the extent of a reaction can be measured or detected using a suitable device for detecting radio frequency changes.

In the present invention, more than one test can be run simultaneously on the same biochip and therefore the certainty of the diagnosis or prognosis can be
5 improved. As the number of markers increases so does the certainty of measurement.

One of the many examples of uses of the biochip/cassette of the present invention is to measure blood proteins indicating peripheral vascular disease using a drop of the patient's blood.

The present invention is also applicable to small particles other than the
10 microsphere beads described herein. In particular, the separation technology of the present invention also works using non-uniform particles including silica-based particles, for example sand grains, even though these particles are not necessarily spherical in shape nor uniform in size, as shown in Example 7 below. Non-uniformity of the particles makes the separation less efficient because it is somewhat slower but
15 effective separation is still achieved, at least for qualitative assays.

For example, in Example 7 using sand grains, the separation does not appear to happen as efficiently since fewer organisms are separated from the sample in the same time period as the separation using microsphere beads as described in Examples 4, 5 and 6. Still, the organisms are successfully separated and can be further tested or
20 assayed accordingly. The use of silica and other similar particles is advantageous over the microsphere beads because they are less expensive and may be more readily available in less developed and developing countries. Thus, the microsphere beads of the present invention can be generalized to a phenomenon of particles in general and the invention is not restricted to spherical beads.

Another advantage of the use of silica-type particles is that silica is known in the art to selectively bind proteins and nucleic acids. Silica-based separation particles could be used to devise certain protein and/or nucleic acid positioning mechanisms.

In all of Examples 4 to 7 the separation was almost instantaneous and the limit
5 on the size of the particles was limited by the type of bacteria, microorganism or other analyte which one wished to isolate. It is expected that one skilled in the art would know which size of particle to select based on the type of bacteria present in the sample. If the bacteria was unknown, then a person skilled in the art would pick a particle size based on the expected size anticipated and select a bead size generally in
10 accordance with the 0.4 to 1 ratio as described above.

The assays and devices of the present invention can be particularly helpful in identifying the presence of harmful and pathogenic bacteria in certain biologic samples, such as *E. coli* strain O157:H7, salmonella, listeria, clamidia and other bacteria and microorganisms such as viruses. For example, the assays of the present
15 invention could be used to test food samples for certain pathogens. They could also be used in human or veterinary medicine for diagnosis of infectious diseases.

Further details of the preferred embodiments of the invention are illustrated in the following Examples which are understood to be non-limiting with respect to the appended claims.

20

Example 1: Verification of Plasma Flow and Separation from Whole

Human Blood

As illustrated schematically in Figures 3 to 6, approximately 15 μ l of 10 μ m latex microsphere beads (Bang's™) 50 were dropped onto a glass slide 52 and

allowed to dry. A glass coverslip 54 was placed on the slide and pushed, on edge, towards and along, the dried beads. The cover slip caused the dried beads to be separated from the glass slide and further caused the collection of dried beads to roll over thereby forming a curl 56. The cover slip was then placed on the slide with the

5 "curl" touching the edge of the coverslip (illustrated in Figures 5 and 6). The coverslip was fixed squarely in place on the slide with one edge aligned parallel to the edge of the curl of dried beads and this edge was left open to allow fluid to pass through the beads and into the capillary chamber formed between the cover slip and the glass slide. The coverslip was attached with nail polish at the corners 58 of the

10 coverslip to secure it to the microscope slide. The coverslip was secured at a spot where no capillary action was intended to take place to permit fluid to flow freely under the coverslip.

A 20 μ l drop of whole human blood 18 was placed on the remaining 5 to 10 μ m microsphere beads. In other words, the sample of whole human blood was placed

15 on the remaining portion of the beads which did not form part of the curl leaving the plasma component free to move by capillary action through the curl portion of the microsphere beads and into the space defined between the coverslip and the slide (i.e. the capillary chamber). The effect was observed under a binocular light microscope. Upon application of the blood sample to the beads the plasma immediately began to

20 separate from the whole blood. As the curl became plasma soaked, capillary action between the coverslip and the slide drew the pure, clean, cell-free plasma under the coverslip into the chamber defined between the coverslip and the slide. This chamber defines a known space, the volume of which can be calculated and predetermined.

This demonstrated that the microsphere beads are able to readily and effectively separate plasma from whole blood and to pass, via the capillary channels formed between the microsphere beads, into the capillary chamber.

5 **Example 2: Microsphere Separation Combined With Chromatography Strip**

In an assay for an analyte in a human blood sample, this example (schematically illustrated in Figure 7) demonstrated the use of microsphere separation of plasma from a blood sample of human whole blood. The plasma was separated using latex microsphere beads (Bang's™) 50 and then drawn into a standard
10 nitrocellulose chromatography strip.

The fiberglass pads, which are usually used to retain red blood cells in the prior art, were replaced with about 20 μ l of 10 μ m latex beads. A drop of human blood (about 60 μ l) was placed on a surface 52', in contact with the latex microspheres. Fiberglass pad 60 effectively functions as a spacer between the beads
15 50 and label pad 64 although it could also be used as a second filter. Fiberglass filter 60 may be eliminated entirely and microsphere beads 50 abut directly with label pad 64 (not illustrated).

It was observed that the blood soaked the bead pile and within about 2 minutes clear plasma ran onto the nitrocellulose chromatography strip. This was observed
20 with the visible eye and also under a microscope. This example demonstrated that the microsphere method for separation of plasma from blood can also be used in conjunction with a standard nitrocellulose chromatography strip. For tests using such chromatography strips this is clearly an advantageous methodology for separating plasma from blood.

Illustrated in Figure 7A is another embodiment where, instead of a fiberglass label pad 62, microsphere beads 66 are used as the label region of the test device. A fiberglass filter pad 60' is used as a spacer between the two sets of beads, 50 and 66.

5 **Example 3: Neural Network Marker Analysis**

A neural network is a mathematical function $N(W,a)$ which takes input analyte vectors $a=(a_1,a_2,\dots,a_n)$ and outputs numbers between 0 and 1. The weight parameters W are adjusted during the training period, using training patterns $\{p=(b_1,b_2,\dots,b_n,T)\}$ where b_1,\dots,b_n are training protein vectors, and T is the target output value. In the case of a coagulation test, T would be 1 for a coagulation result, and 0 for a non-coagulation result.

The parameters W are adjusted to minimize the error $E = \sum_p (N(W,a) - T)^2$

while maintaining good performance on new test data.

15 Once the network is trained, a network cutoff C is chosen to classify test data. Let $TST(C,b,T)$ be the test result for a testing vector a , given cutoff C , and target output T .

$$TST(C,b,T) = \begin{cases} 1 & \text{if } N(a) > C \\ 0 & \text{otherwise} \end{cases}$$

20 Now, we can analyze the sensitivity and specificity of the test.

True Positive if $T=1$ and $TST(C,b,T)=1$

False Positive if $T=0$ and $TST(C,b,T)=1$

True Negative if $T=0$ and $TST(C,b,T)=0$

False Negative if $T=1$ and $TST(C,b,T)=0$

Sensitivity = $TP/(TP+FN)$

Specificity = $TN/(TN+FP)$

- 5 Plotting sensitivity versus 1-specificity for various cutoffs gives a ROC (receiver operator characteristic) curve.

NEURAL NETWORKS

We start with a set of training patterns $\{ p=(I_1, I_2 \dots I_n, TAR)$, where I_j is an input value, and TAR is the target value ($TAR = 0$ or $TAR = 1$). We want to train a neural network to give outputs which are close to the target values.

A neural network has 3 layers; the first INPUT layer, the second HIDDEN layer, and the third OUTPUT layer:

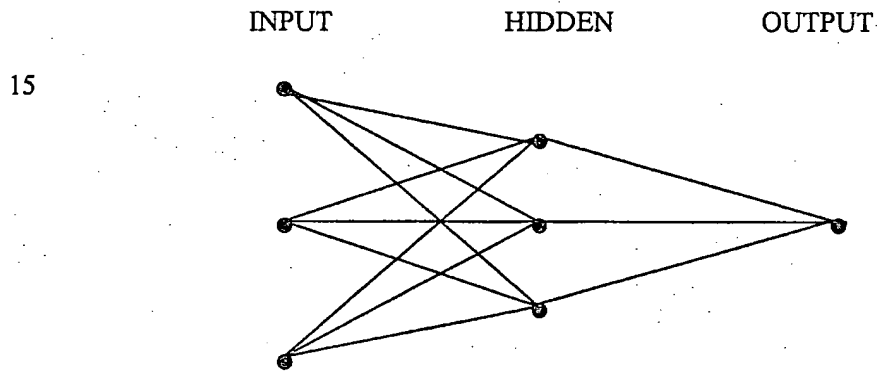

15

20

The neurons are connected by a set of weights $\{w(i,j,k)\}$. For example, $w(1,2,4)$ connects the second neuron of the first layer with the fourth neuron of the second layer.

For each pattern we assign a number called the activation to each neuron, which measures the probability that it is firing. The activation is defined recursively as follows:

$$a(i,j) = \begin{cases} I_j & \text{if } i=1 \\ 1 / (1 + \exp(-\sum_k \{w(i-1,k,j)a(i-1,k)\})) & \end{cases}$$

The error is calculated as

$$ERMS = \text{SQRT} \{ \sum \{ (t - a(2,1))^2 \} \}$$

where the sum is over all patterns.

The weights are adjusted to minimize ERMS, while maintaining good performance on new data.

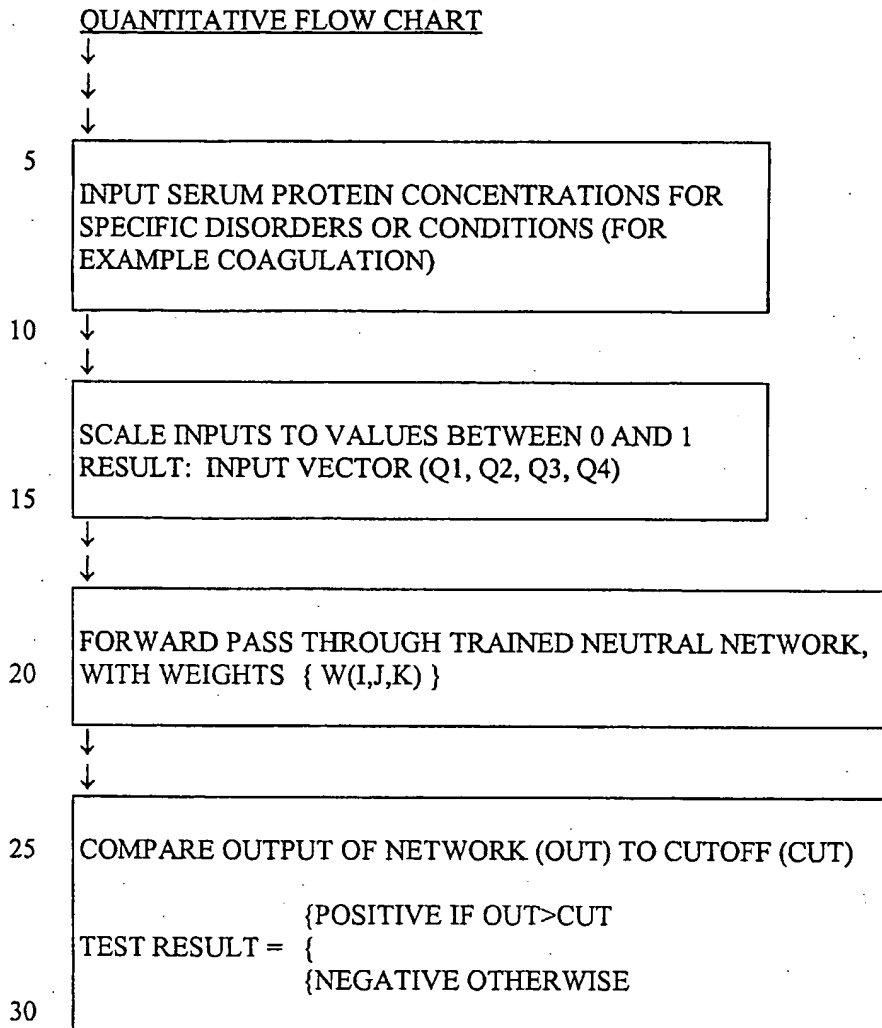

Example 4: Separation of *Lactobacillus* from Yogurt

Approximately 10 μ l of yogurt containing *Lactobacillus* bacteria was placed on a biochip. When no separation beads are present on the biochip, solid particles are observed in the field of view (in addition to the lactobacilli present in the yogurt), as seen in Figure 9. Before separation, only a few bacteria can be seen in the field (Figure 9).

In contrast, as shown in Figure 10, separation through microsphere beads having a diameter of 15 μm shows a good separation of bacteria from the sample. None of the solid particles seen in Figure 9 appear. After separation, only bacteria are seen in the separated fluid portion (Figure 10). Separation occurred almost
5 instantaneously. The microsphere beads provided a quick and ready separation step for isolation of the bacteria away from the rest of the solid particles in the yogurt thereby permitting further testing on the separated bacteria. This would permit a determination of the type of bacteria present in a sample. For example, the type of bacteria, or other microorganism, could be determined by a specific antigenic test to
10 determine the type of bacteria or microorganism present.

A similar result is seen in Figure 11 when the separation was done using 10 μm microsphere beads. Figure 11 shows a fewer number of bacteria per field but is still shows an effective separation of bacteria from the yogurt.

15 **Example 5: Separation of *E. coli* from a Bread Suspension**

In this example, *Escheria coli* (*E. coli*) was successfully separated from a bread suspension using the methodology and apparatus of the present invention.

First, a bread and NaCl mixture was prepared. 200 mg of bread was weighed. A bread suspension was prepared by repeatedly mixing 500 μl 150 mM NaCl with the
20 bread. *E. coli* (strain: DH5 α) was added in a 100 μl aliquot to the bread suspension. The suspension was mixed again to create an *E. coli*/bread suspension. 100 μl of the *E. coli*/bread suspension was placed on the biochip and almost instantaneously the microsphere beads acted to partition a fluid component containing bacteria from the sample but none of the solid particles from the suspension. Figure 12 shows a typical

field of view of the unseparated *E. coli*/bread suspension. Figure 13 shows the clean separation of bacteria in the fluid portion isolated using microsphere beads having a 15 μm diameter. A good separation was observed.

5 **Example 6: Separation of Bacteria From Cow Feces**

In this example, bacteria from cow feces were separated using the technology of the present invention. 500 mg of cow feces were combined with 500 μl 150 mM NaCl and mixed to form a suspension. A 5 μl sample of the suspension was used for separation and placed on the biochip. Photomicrographs before separation (Figure 14) and after separation (Figures 15 and 16) are shown. Separation in this example was achieved using 15 μm microsphere beads. The sample was placed on the biochip and almost instantaneously the microsphere beads partitioned out a fluid component containing bacteria. The separated bacteria can now be stained to further identify them. A good separation was achieved using 15 μm beads (Figure 15) and also with 10 μm diameter beads (Figure 16).

Example 7: Separation Using Silica Sand Particles

In this example, other types of particles were tested in addition to the standard polystyrene beads which are commercially available. In order to test the suitability of silicone-based particles, sand grains (silica sand) replaced the microsphere beads. Three tests were done: cow feces, *E. coli*/bread suspension, and blood. The silica sand was mixed with water to form a slurry and applied to the biochip. The size of the sand particles on the biochip can be seen from the 1 mm reference scale (Figure 17).

While good separation was observed, as illustrated in Figures 8 for cow feces and Figure 19 for the *E. coli*/bread suspension, the separation was not as good as the same experiments set out in Examples 5 and 6, above, in which polystyrene beads were used for the filtration step. The less efficient separation using the sand grains was probably due to the non-uniformity of particle sizes and shapes. However, it is clear that the use of sand grains/silica sand is still a suitable alternative to the use of polystyrene microsphere beads as clean separations are still achieved.

Whole blood was applied to the biochip and allowed to filter through the silica sand particles. In this case, due to the larger particle sizes (as compared to the 10 μ m microsphere beads) the red blood cells flowed through the filtration particles. A uniform blood smear was obtained.

Example 8: Detection of *E. coli* strain O157:H7 in Various Food Samples

Food samples (25 gm or 25 ml) spiked with various amounts of *E. coli* strain O157:H7 were enriched for bacterial growth in various media for 18 hours at 37 °C with shaking at 150 RPM. The media tested were: BPW-VC (buffered peptone water with vancomycin and cefsulodin); mEC broth (Merck); mTSB (trypticase soy broth containing novobiocin, Merck); and CASO broth (Merck). Food samples investigated were raw milk, ground beef, cheese spread, and soft cheese (Camambert). A portion of the enriched sample was then stained with Alexa 594-labeled anti-O157 antibody. The stained sample was then passed into a biochip without microsphere beads and stained bacteria visualized using a DNAscope. The biochip assay was compared to a conventional lateral flow assay.

It was found that the media used to enrich the had an influence on the sensitivity of the procedure. However, in general, the biochip assay was more sensitive than the conventional lateral flow assays. In general, using a conventional lateral flow test, 4×10^6 cfu/ml bacteria were required to obtain a positive result in the lateral flow assay, compared to between 6×10^3 to 4×10^4 cfu/ml bacteria for the Biochip assay, depending on the *E. coli* O157:H7 strain. Thus, the biochip assay was between about 100-1,000 times more sensitive than the lateral flow assay.

Raw milk: *E. coli* O157:H7 strain ATCC#700531 was spiked into raw milk (70 cfu (colony-forming units) of bacteria), and the resulting mixture grown in various culture media. The biochip assay was able to detect bacteria when the raw milk sample was enriched in CASO broth and BPW-VC, and a weakly positive result was obtained when the raw milk sample was enriched in mEC media. However, no bacteria were detectable when the raw milk sample was grown in mTSB media. Similar results were obtained in a conventional lateral flow test, except that no bacteria were detected in a raw milk sample enriched in mEC media.

Ground beef: *E. coli* O157:H7 strain ATCC#700531 was spiked into ground beef sample grown in BPW-VC, CASO broth or mEC media. Using the conventional lateral flow assay, it was found that that the lower limit of detection of the culture enriched in BPW-VC or CASO broth was 3 cfu added to the sample, and the bacteria were not detected in the sample enriched in mEC media. In the biochip assay, the lower limit of detection in the BPW-VC medium was a nominal 0.3 cfu added to the sample.

Soft cheese (Camambert): *E. coli* O157:H7 strain ATCC#35150 was spiked into ground beef samples grown in BPW-VC, CASO broth or mEC media. The

samples were spiked with 0, 0.2, 2, or 20 cfu bacteria. The bacteria grew well in mEC culture, but not in CASO broth. Using the lateral flow test, bacteria were detected in the BPW-VC cultures at 2 cfu and 20 cfu, and in mEC cultures at 20 cfu. Similar results were obtained using the biochip assay. However, some food samples that have a high fat content, such as milk and cheese, contain autofluorescent materials that interfere with detection by immunofluorescent staining. Proper separation by the microsphere beads allows only the bacteria in the sample to enter the chip, thereby reducing the background interference and enhancing the sensitivity of the detection method.

10 **Ground chicken:** *E. coli* O157:H7 strain ATCC#35150 was spiked into ground chicken samples grown in BPW-VC, CASO broth or mEC media. While there were significant levels of background bacterial growth, the biochip assay was able to detect 1 cfu bacteria in a BPW-CV-enriched sample, which was negative by the lateral flow assay.

15

Example 9: Detection Limit of *E. coli* O157 in Pure Culture and Ground Beef with or without Microsphere Beads

The experiment was designed to compare the detection limits of *E. coli* O157 in pure bacterial culture, with or without treatment using microsphere beads. A pure culture of bacteria was ten-fold serially diluted using CASO broth between 10^1 and 10^{-7} . The samples diluted to 10^{-3} , 10^{-4} , 10^{-5} , 10^{-6} and 10^{-7} were stained with Alexa Fluor 594-labeled anti-*E. coli* O157 antibody (diluted 1:25). These samples were applied to biochips containing 15 μ m diameter microsphere beads (5 μ l) or without

microsphere beads (2 μ l), then counted. No difference in the detection limit was found in samples treated with or without microsphere beads.

A similar experiment was performed using ground beef spiked with *E. coli* O157:H7 ATCC #35150 (37, 4, or 0 cfus) cultured in mEC broth. After 18 hrs, samples were stained with Alexa Fluor 594-labeled anti-*E. coli* O157 antibody, and applied to biochips with or without microsphere beads. No difference in the bacterial counts was found between the samples treated with microsphere beads and those not treated with microsphere beads.

10 Example 10: Concentration of Fluid Samples Using Polymer Gel

Fluid samples may be concentrated by contacting the sample with a superabsorbent polymer, such as those containing acrylamide and/or dextran, which are capable of absorbing large amounts of water and/or small ionic species.

Preferably, the superabsorbent polymer is a non-ionic polymer. In particular, the concentration of bacteria in a fluid sample can be easily achieved using this method. The superabsorbent polymer may be held in a syringe or other suitable container, and the sample mixed with the polymer while in the syringe. The polymer gel in the syringe may also include another molecule to be exposed to the sample during the concentration step, such as, for example, a labeled monoclonal antibody. After the concentration step is completed, the concentrated sample may then be expressed from the syringe for further treatment. For example, the concentrated sample may be treated as described above to separate a non-fluid component from a fluid component for further testing.

To test the size exclusion characteristics of the polymer gel, the gel was incubated with solutions containing polystyrene beads (0.01%, w/v) ranging in diameter from 15 μm to 0.3 μm (15, 10, 5, 2, 1, 0.4, and 0.3 μm). The beads first were counted and their concentration was expressed in terms of number of beads/ml.

5 The beads then were concentrated by incubation with the polymer gel, and the numbers of beads/ml recounted and compared to the untreated sample of the same beads. It proved impossible to reliably detect and count the beads having a diameter smaller than 5 μm . However, for 15 μm beads, the gel concentrated the beads by a factor of 2.2 - that is, the number of beads/ml increased 2.2-fold. For 10 μm beads,

10 the gel concentrated the beads by a factor of 4.3. For 5 μm beads, the gel concentrated the beads by a factor of 5.7-fold.

Although the invention herein has been described with reference to particular embodiments, it is to be understood that these embodiments are merely illustrative of various aspects of the three template generating methods and the amino acid

15 assignment methods of the invention. Thus, it is to be understood that numerous modifications may be made in the illustrative embodiments and other arrangements may be devised without departing from the spirit and scope of the invention, as encompassed in the following claims. Throughout this application various publications may be cited. Where cited, the contents of these publications are hereby

20 incorporated by reference into the present application.

What is claimed is:

1. A device for assaying a fluid sample, comprising:
 - a chamber, said chamber being defined by two non-contiguous surfaces;
 - said chamber having at least one fluid entrance;
 - said non-contiguous surfaces being separated by a distance sufficient to create capillary flow of said fluid sample into said chamber through said at least one fluid entrance;
 - a dynamic capillary filter, said dynamic capillary filter being in fluid communication with said fluid entrance and further including a plurality of particles, said particles being in a transiently abutting relation with one another and forming interstitial spaces therebetween;
 - whereby when said fluid sample contacts said dynamic capillary filter, said fluid sample flows into said dynamic capillary filter, whereupon a fluid component of said fluid sample is separated from a non-fluid component of said fluid sample by passage through said interstitial spaces of said dynamic capillary filter and said fluid component thereafter flows into said chamber through said fluid entrance.
2. The device of claim 1, wherein said non-contiguous surfaces are opposing planar surfaces.
3. The device of claim 1, wherein said chamber has a defined volume.

4. The device of claim 1, wherein said particles are at least one member selected from the group consisting of microspheres, glass particles, silica particles, and sand particles.
5. The device of claim 1, wherein said particles are microspheres.
6. The device of claim 5, wherein said microspheres are of a uniform shape and size.
7. The device of claim 6, wherein said microspheres have a mean diameter of 10 μm .
8. The device of claim 6, wherein said particles produce interstitial pore sizes of 4 μm .
9. The device of claim 6, wherein said particles have a mean diameter of 15 μm .
10. The device of claim 6, wherein said particles produce interstitial pore sizes of 6 μm .
11. The device of claim 5, wherein said microspheres are contained in a fluid permeable material.
12. The device of claim 4, wherein said particles contain a label effective to identify at least one component of said fluid sample upon interaction of said component with said label.

13. The device of claim 1, wherein said particles are of a non-uniform shape or size.
14. The device of claim 13, wherein said particles are a member of the group consisting of glass particles, silica particles, and sand particles.
15. The device of claim 5, further comprising a plurality of smaller particles, said plurality of smaller particles being interspersed among said microspheres.
16. The device of claim 15, wherein said plurality of smaller particles are microspheres.
17. The device of claim 15, wherein said smaller particles contain a label effective to identify at least one component of said fluid sample upon interaction of said component with said label.
18. The device of claim 17, wherein said label is a member selected from the group consisting of a radioactive label, a fluorescent label, a metal label, a peptide, and a protein.
19. The device of claim 17, wherein said label is an antibody.
20. The device of claim 15, wherein:

said plurality of smaller microspheres comprises a plurality of groups of smaller microspheres, each of said groups of smaller microspheres containing a different one of a plurality of labels effective to identify at least one component of said fluid sample upon interaction of said component with said label; and

each of said groups of smaller microspheres being interspersed among said plurality of particles in a separate zone of said microspheres.

21. The device of claim 1, further comprising a plurality of chambers.
22. The device of claim 1, wherein said chamber is divided into a plurality of lanes, each of said lanes having a defined length and width.
23. The device of claim 1, further comprising a wick capable of removing said fluid component from said chamber.
24. The device of claim 1, further comprising chromatography test strips capable of separating components of said fluid component.
25. The device of claim 1, further comprising a filter pad impregnated with a label.
26. The device of claim 25, wherein said filter pad is located between said dynamic capillary filter and said chamber.
27. The device of claim 25, wherein said filter pad contains fiberglass.

28. The device of claim 25, wherein said filter pad contains cellulose.
29. The device of claim 1, further comprising a reagent bound to an interior face of at least one of said non-contiguous surfaces of said chamber, said reagent being capable of reacting with one or more analytes that may be present in said fluid sample.
30. The device of claim 29, wherein said reagent is an antibody.
31. The device of claim 29, wherein said reagent is an antibody directed against an extracellular antigen of an enteric bacterium.
32. The device of claim 29, wherein said reagent is an antibody directed against an extracellular antigen of *Escherichia coli* O157:H7.
33. The device of claim 29, wherein said reagent is capable of being bound by at least one of said one or more analytes that may be present in said fluid sample.
34. The device of claim 1, wherein said plurality of particles have a size that is capable of permitting bacterial cells to pass into said chamber while excluding particles having a size greater than that of bacterial cells.

35. The device of claim 1, wherein said plurality of particles have a size that is capable of excluding red blood cells from passing into said chamber.
36. The device of claim 1, further comprising:
a well in one of said non-contiguous surfaces;
said well being capable of holding in place said plurality of particles;
said well further having a outlet in fluid communication with said fluid entrance.
37. The device of claim 36, wherein said outlet is a hole.
38. The device of claim 37, further comprising a ball, said ball being capable of sitting in said hole, said ball further having a diameter that is less than 10 μm less than a mean diameter of said hole.
39. The device of claim 36, wherein said outlet is a channel, said channel having a long dimension perpendicular to a direction of travel of said fluid into said chamber.
40. The device of claim 39, further comprising a rod, said rod being capable of sitting in said channel, said rod further having a diameter that is less than 10 μm less than a mean diameter of said channel and having a length that is substantially equal to that of said channel.
41. The device of claim 1, wherein said non-contiguous surfaces are made of a plastic.

42. The device of claim 41, wherein said plastic is polystyrene.

43. The device of claim 1, further comprising a cap slidably disposed on said device and capable of covering said chamber and said dynamic capillary filter.

44. An assay device, comprising in combination:

a chamber, said chamber being defined by two non-contiguous surfaces;

said chamber having at least one fluid entrance;

said non-contiguous surfaces being separated by a distance sufficient to create capillary flow of said fluid sample into said chamber through said at least one fluid entrance;

a dynamic capillary filter, said dynamic capillary filter being in fluid communication with said fluid entrance and further including a plurality of particles, said particles being in abutting relation with one another and forming interstitial spaces therebetween;

whereby when said fluid sample contacts said dynamic capillary filter, said fluid sample flows into said dynamic capillary filter, whereupon a fluid component of said fluid sample is separated from a non-fluid component of said fluid sample by passage through said interstitial spaces of said dynamic capillary filter and said fluid component thereafter flows into said chamber through said fluid entrance;

a reagent bound to an interior face of at least one of said non-contiguous surfaces, said reagent being capable of reacting with one or more analytes that may be present in said fluid sample; and

an analyzer, said analyzer being capable of detecting a reaction between said reagent and at least one of said one or more analytes that may be present in said fluid sample.

45. The assay device of claim 44, wherein said particles are at least one member selected from the group consisting of microspheres, glass particles, silica particles, and sand particles.

46. The assay device of claim 44, wherein said particles are microspheres.

47. The assay device of claim 46, wherein said microspheres are of a uniform shape and size.

48. The assay device of claim 47, wherein said microspheres have a mean diameter of 10 μm .

49. The assay device of claim 47, wherein said particles have pore sizes of 4 μm .

50. The assay device of claim 47, wherein said microspheres have a mean diameter of 15 μm .

51. The assay device of claim 47, wherein said particles have pore sizes of 4 μm .

52. The assay device of claim 46, wherein said microspheres are contained in a fluid permeable material.
53. The assay device of claim 46, wherein said particles contain a label effective to identify at least one component of said fluid sample upon interaction of said component with said label.
54. The assay device of claim 44, wherein said particles are of a non-uniform shape or size.
55. The assay device of claim 54, wherein said particles are a member of the group consisting of glass particles, silica particles, and sand particles.
56. The assay device of claim 46, further comprising a plurality of smaller particles, said plurality of smaller particles being interspersed among said microspheres.
57. The assay device of claim 56, wherein said plurality of smaller particles are microspheres.
58. The assay device of claim 56, wherein said smaller particles contain a label effective to identify at least one component of said fluid sample upon interaction of said component with said label.

59. The assay device of claim 53, wherein said label is a member selected from the group consisting of a radioactive label, a fluorescent label, a metal label, a peptide, and a protein.
60. The assay device of claim 53, wherein said label is an antibody.
61. The assay device of claim 56, wherein:
said plurality of smaller microspheres comprises a plurality of groups of smaller microspheres, each of said groups of smaller microspheres containing a different one of a plurality of labels effective to identify at least one component of said fluid sample upon interaction of said component with said label; and
each of said groups of smaller microspheres being interspersed among said plurality of particles in a separate zone of said microspheres.
62. The assay device of claim 44, further comprising a plurality of chambers.
63. The assay device of claim 44, wherein said chamber is divided into a plurality of lanes, each of said lanes having a defined length and width.
64. The assay device of claim 44, further comprising a wick capable of removing said fluid component from said chamber.
65. The assay device of claim 44, further comprising chromatography test strips capable of separating components of said fluid sample.

66. The device of claim 44, further comprising a filter pad impregnated with a label.
67. The device of claim 66, wherein said filter pad is located between said dynamic capillary filter and said chamber.
68. The device of claim 66, wherein said filter pad contains fiberglass.
69. The device of claim 66, wherein said filter pad contains cellulose.
70. The device of claim 44, further comprising a reagent bound to an interior face of at least one of said non-contiguous surfaces of said chamber, said reagent being capable of reacting with one or more analytes that may be present in said fluid sample.
71. The assay device of claim 44, wherein said reagent is an antibody.
72. The device of claim 44, wherein said reagent is an antibody directed against an extracellular antigen of an enteric bacterium.
73. The device of claim 44, wherein said reagent is an antibody directed against an extracellular antigen of *Escherichia coli* O157:H7.

74. The assay device of claim 44, wherein said reagent is capable of being bound by at least one of said one or more analytes that may be present in said fluid sample.
75. The assay device of claim 44, wherein said plurality of particles have a size that is capable of permitting bacterial cells to pass into said chamber while excluding particles having a size greater than that of bacterial cells.
76. The assay device of claim 44, wherein said plurality of particles have a size that is capable of excluding red blood cells from passing into said chamber.
77. The device of claim 44, wherein said non-contiguous surfaces are made of a plastic.
78. The device of claim 77, wherein said plastic is polystyrene.
79. The device of claim 44, further comprising a cap slidably disposed on said device and capable of covering said chamber and said dynamic capillary filter.
80. A method for detecting or measuring the amount of a component of a fluid sample, comprising the steps of:
- a) providing an assay device that includes:
 - a chamber, said chamber being defined by two non-contiguous surfaces;
 - said chamber having at least one fluid entrance;

said non-contiguous surfaces being separated by a distance sufficient to create capillary flow of said fluid sample into said chamber through said at least one fluid entrance;

a dynamic capillary filter, said dynamic capillary filter being in fluid communication with said fluid entrance and further including a plurality of particles, said particles being in abutting relation with one another and forming interstitial spaces therebetween;

whereby when said fluid sample contacts said dynamic capillary filter, said fluid sample flows into said dynamic capillary filter, whereupon a fluid component of said fluid sample is separated from a non-fluid component of said fluid sample by passage through said interstitial spaces of said dynamic capillary filter and said fluid component thereafter flows into said chamber through said fluid entrance;

a reagent bound to an interior face of at least one of said non-contiguous surfaces, said reagent being capable of reacting with one or more analytes that may be present in said fluid sample; and

an analyzer, said analyzer being capable of detecting a reaction between said reagent and at least one of said one or more analytes that may be present in said fluid sample;

b) applying said fluid sample to said assay device under conditions under which said fluid sample passes through said dynamic capillary filter and thereafter a fluid component of said fluid sample passes into said chamber through said fluid entrance;

- c) detecting a presence of a reaction product formed as a result of a reaction between said reagent and said one or more analytes that may be present in said fluid sample; and
- d) optionally, measuring at least one of an amount of and a concentration of said reaction product.

81. The method of claim 80, wherein said fluid sample is a member selected from the group consisting of a blood sample, a blood-derived sample, a food sample, a fecal sample, and a water sample.

82. The method of claim 81, wherein said fluid sample is a blood sample.

83. The method of claim 82, wherein said fluid sample is a rodent blood sample.

84. The method of claim 81, wherein said fluid sample is an aqueous suspension of a food sample.

85. The method of claim 81, wherein said fluid sample is a water sample.

86. The method of claim 82, wherein a plasma-containing portion of said blood sample is separated from a cell-containing portion of said blood sample upon passage through said dynamic capillary filter; and thereafter, said plasma-containing portion passes into said chamber through said fluid entrance.

87. The method of claim 84, wherein a cell-containing portion of said aqueous suspension of a food sample is separated from a non-cell-containing portion of said aqueous suspension of a food sample upon passage through said dynamic capillary filter; and

thereafter, said cell-containing portion passes into said chamber through said fluid entrance.

88. The method of claim 85, wherein a cell-containing portion of said water sample is separated from a non-cell-containing portion of said water sample upon passage through said dynamic capillary filter; and

thereafter, said cell-containing portion passes into said chamber through said fluid entrance.

89. A method for assessing a pre- or post-symptomatic health condition of a patient, comprising the steps of:

- a) obtaining a fluid sample from said patient;
- b) analyzing said fluid sample for the presence, absence, and optionally a concentration or amount of an analyte;
- c) repeating steps a) and b) a desired number of times, said desired number being at least once, to create a data pool for said patient;
- d) constructing a database, based on said patient's medical history, current health and said data pool;

e) inputting numerical values from said database into a neural network algorithm, said neural network algorithm being optimized to produce an output predictive of a health outcome from said numerical values; and

f) producing a predicted health outcome from output.

90. The method of claim 89, further comprising encoding said neural network algorithm on a microchip, said microchip being included in the assay device of claim 44.

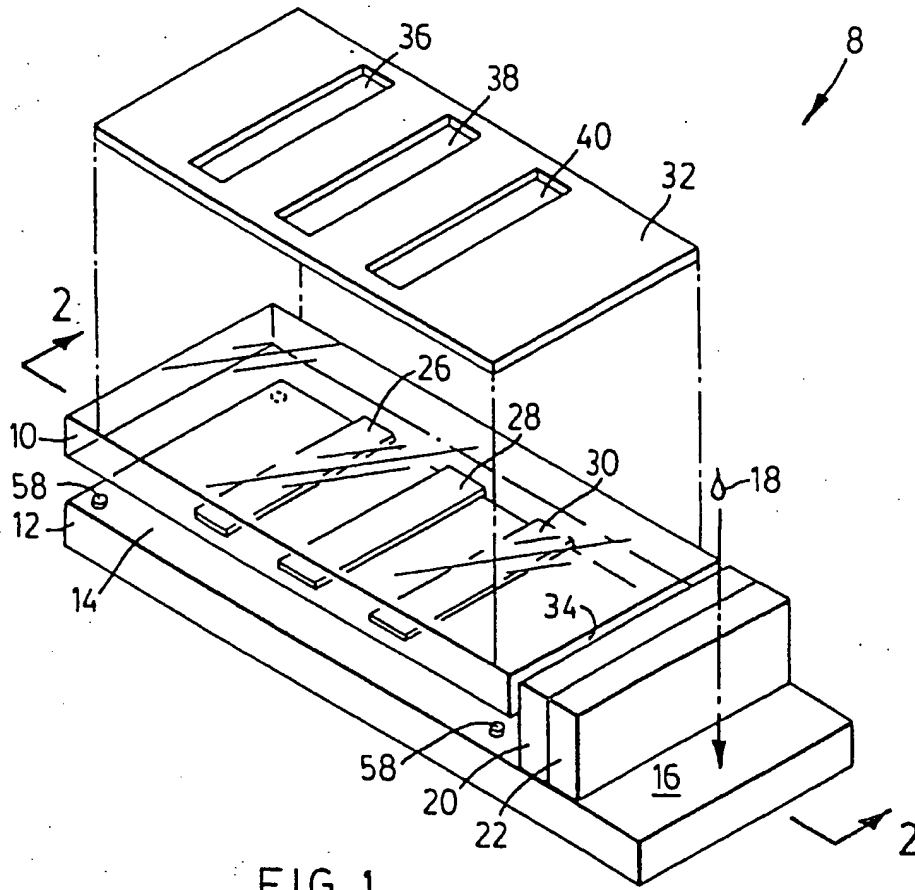

FIG. 1

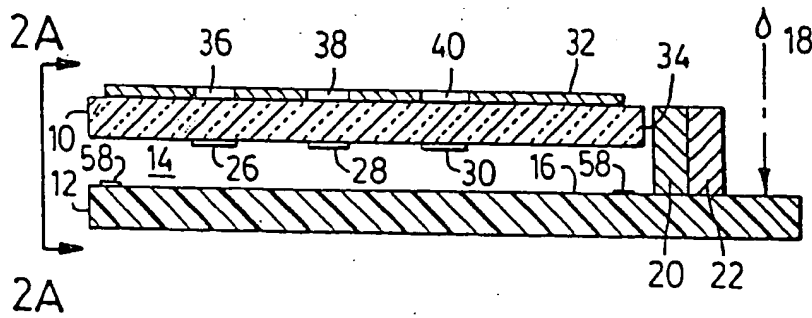

FIG. 2

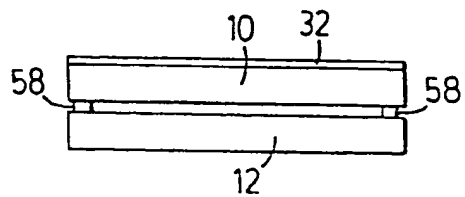

FIG. 2A

2/15

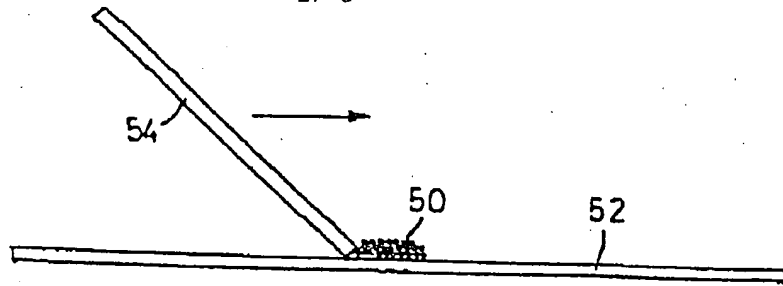

FIG. 3

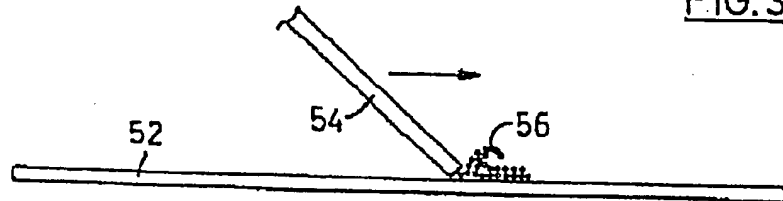

FIG. 4

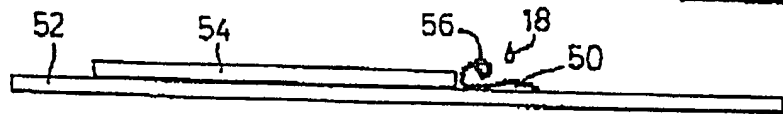

FIG. 5

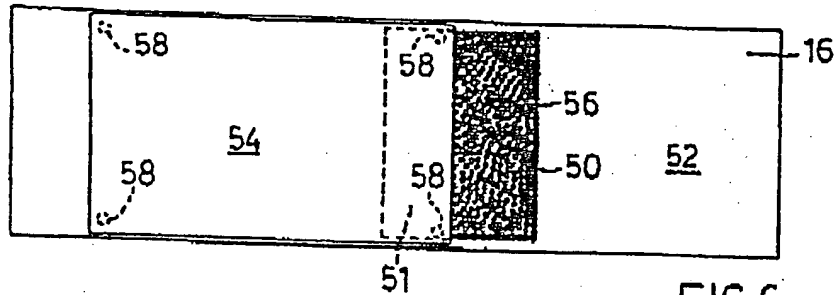

FIG. 6

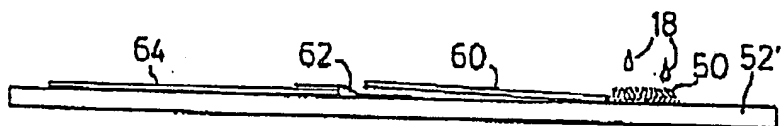

FIG. 7

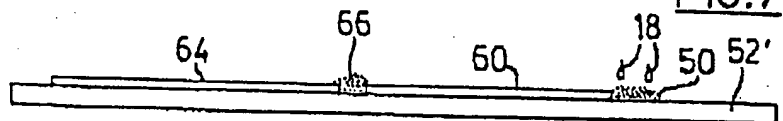
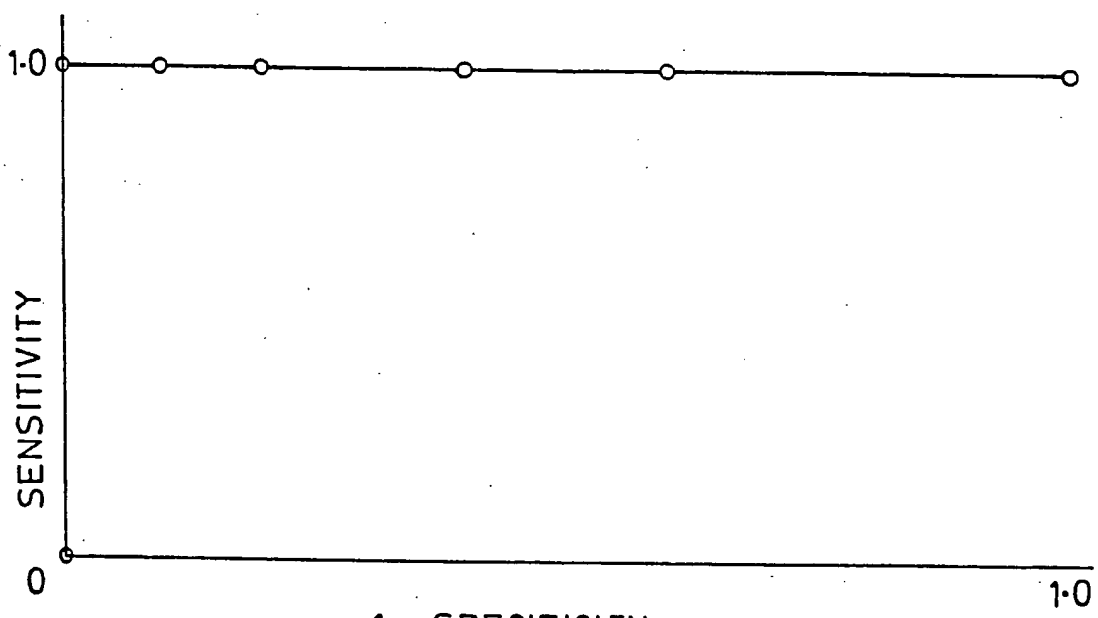

FIG. 7a



1 - SPECIFICITY
AREA UNDER CURVE # 1 : 1.00

FIG. 8

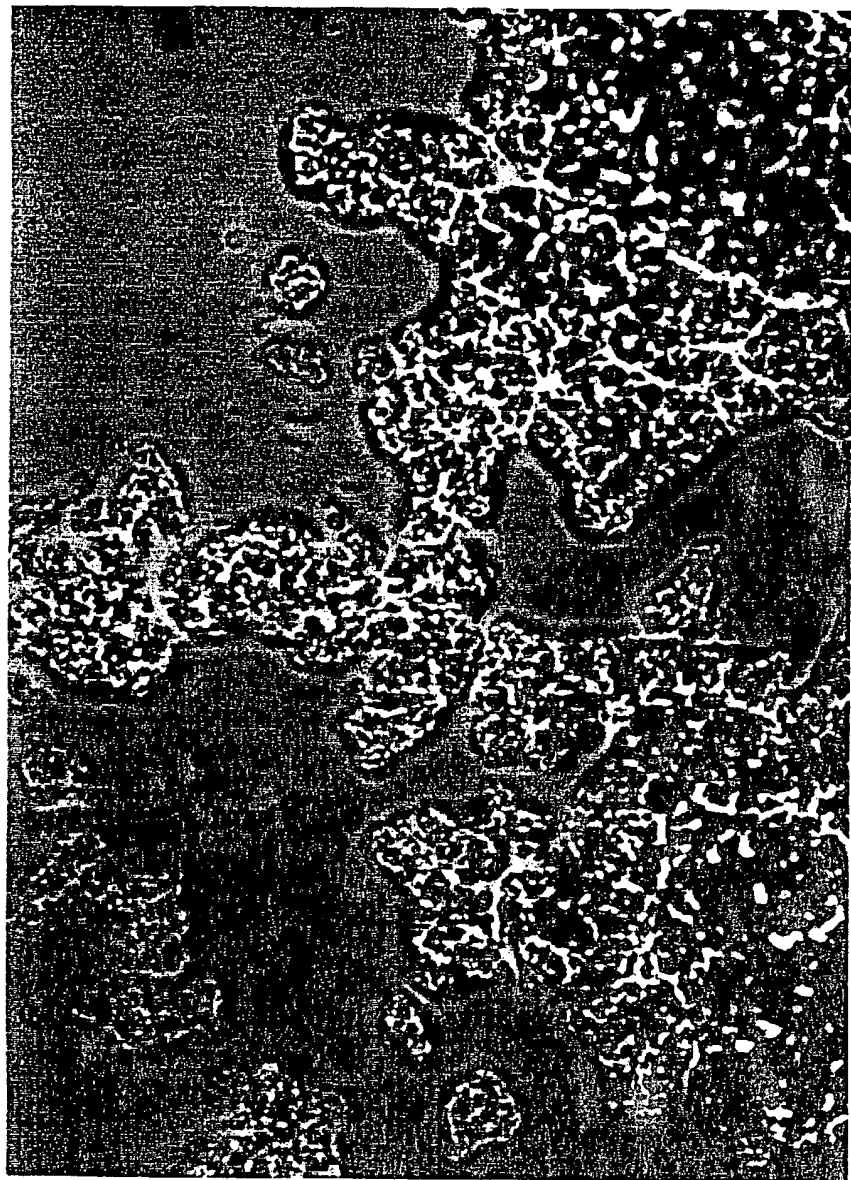

FIGURE 9

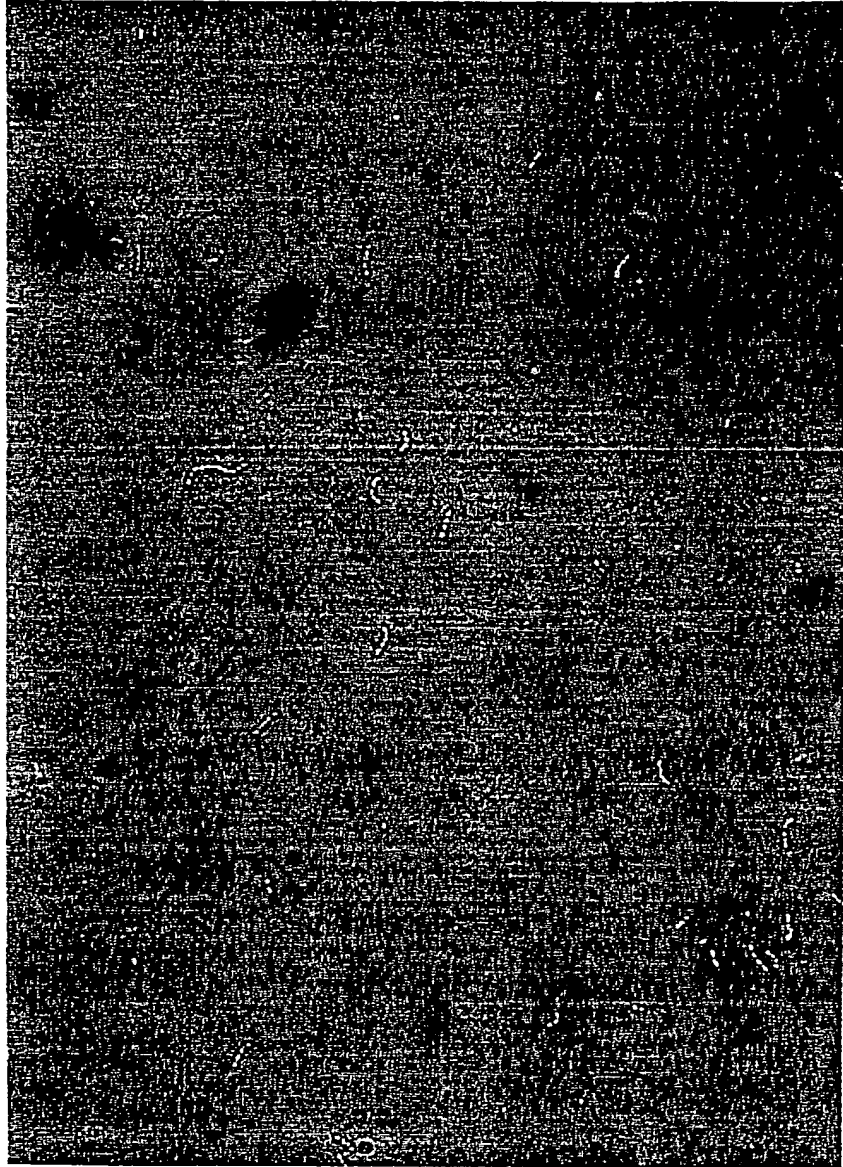

FIGURE 10

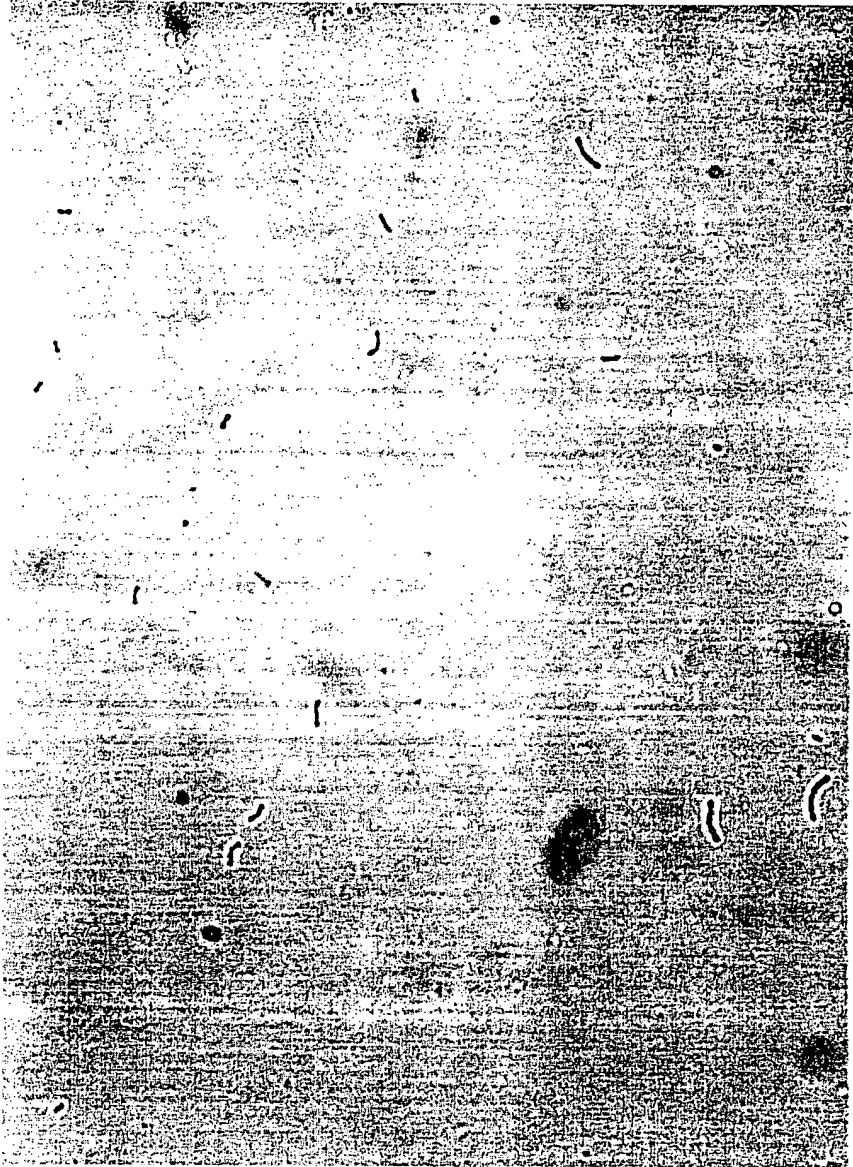

FIGURE 11

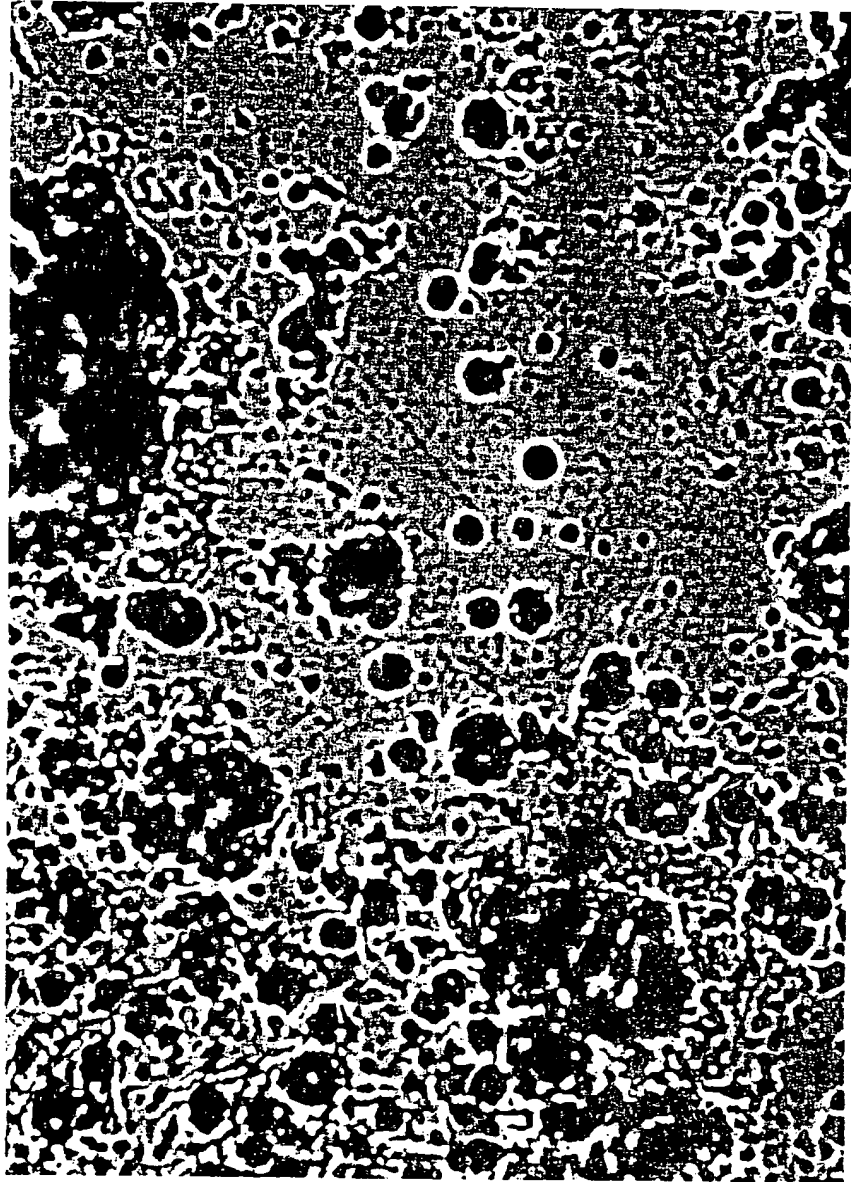

FIGURE 12



FIGURE 13

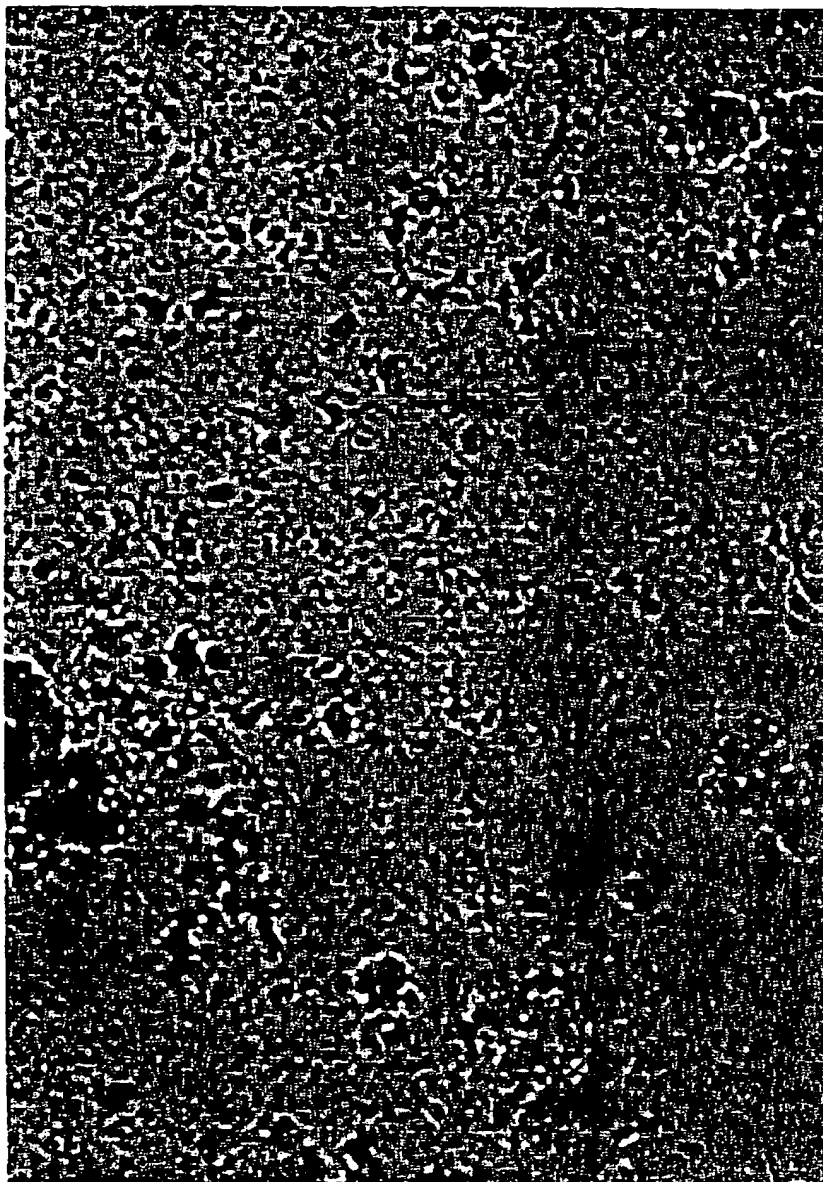

FIGURE 14



FIGURE 15

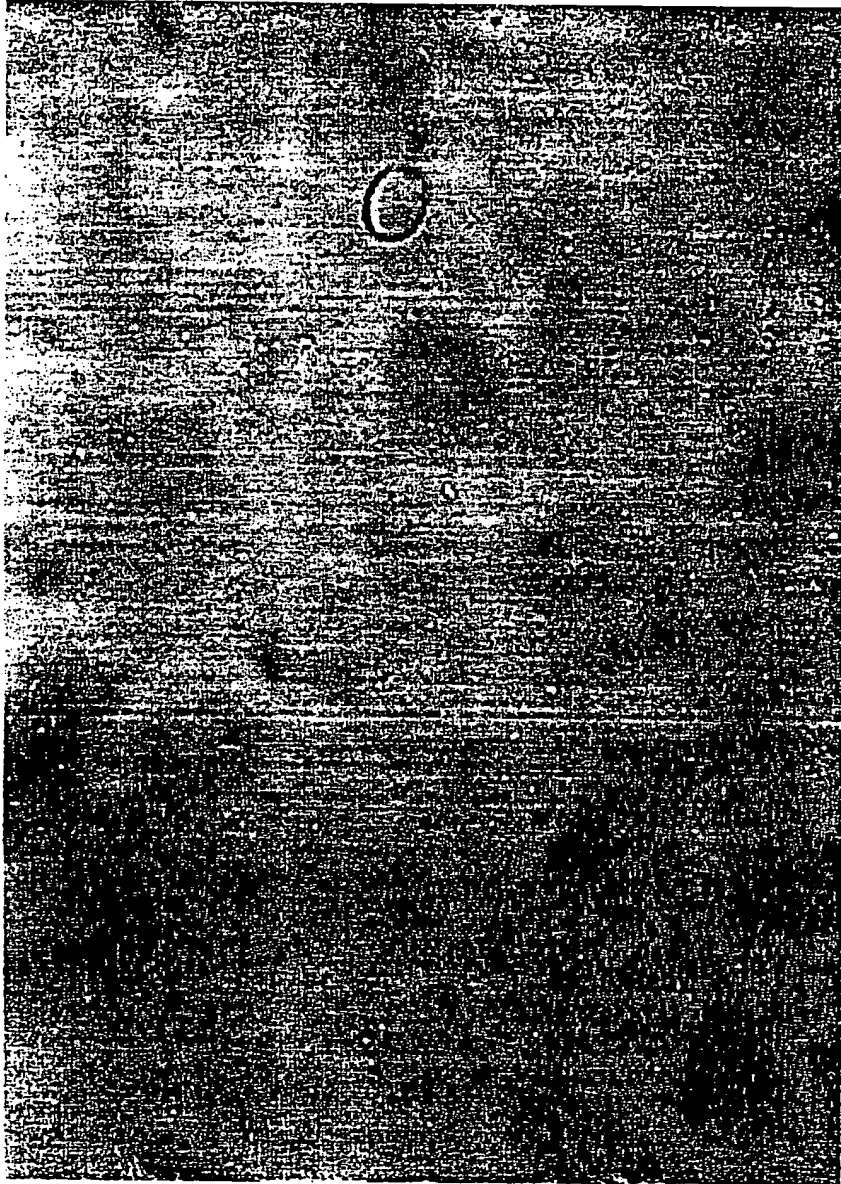

FIGURE 16

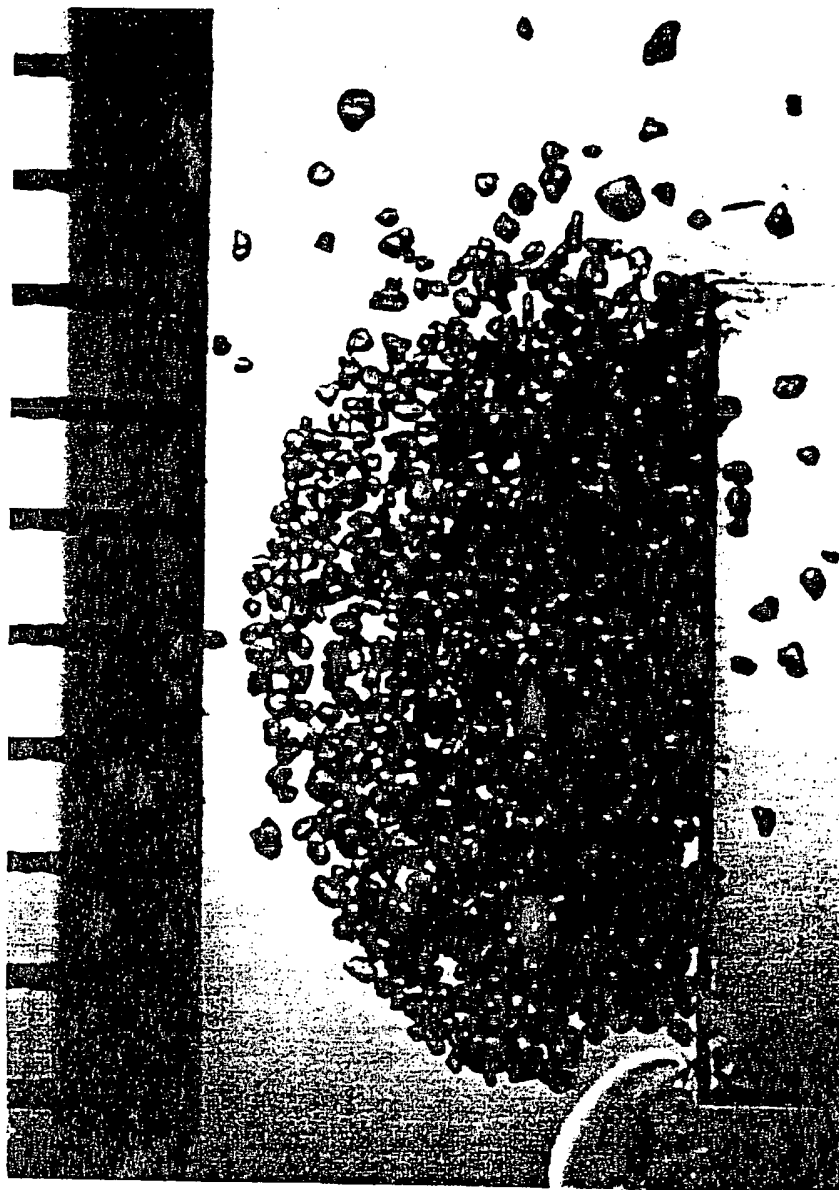

FIGURE 17



FIGURE 18



FIGURE 19

Figure 20A

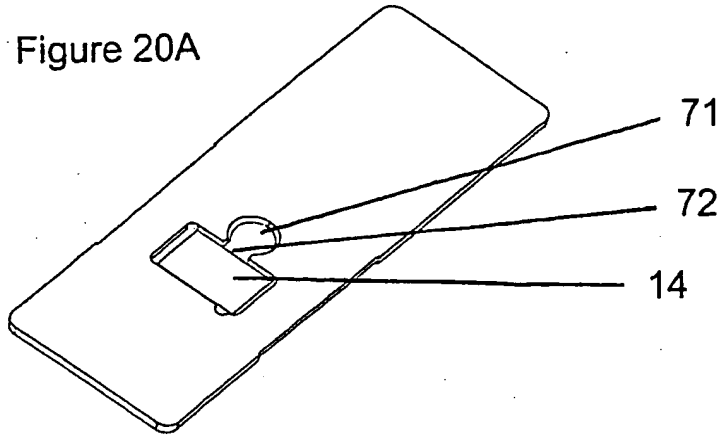

Figure 20B

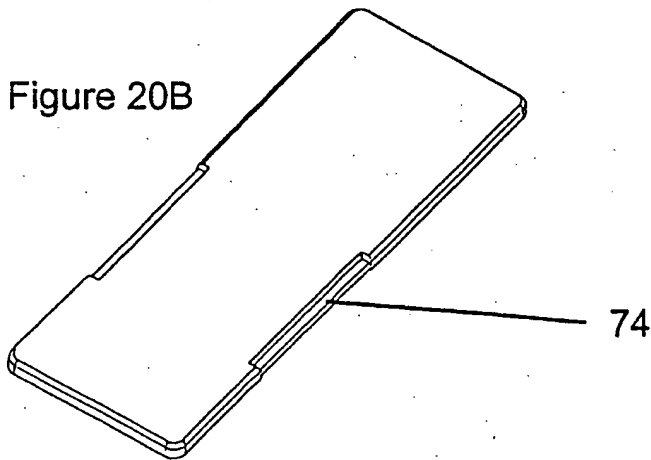
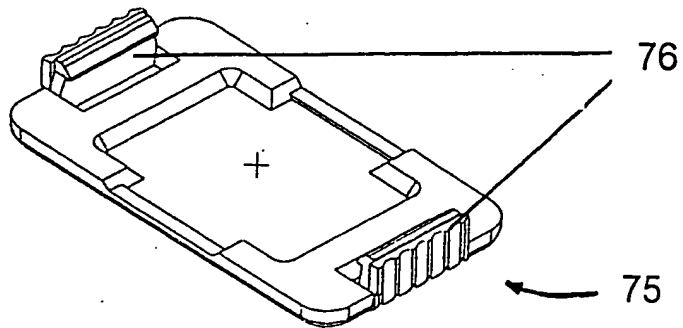

Figure 21



INTERNATIONAL SEARCH REPORT

International application No.

PCT/US00/13056

A. CLASSIFICATION OF SUBJECT MATTER
 IPC(6) : C12M 1/00; G01N 33/543, 551, 552, 553
 US CL : 435/287.1, 288.5; 436/523, 524, 525, 527
 According to International Patent Classification (IPC) or to both national classification and IPC

B. FIELDS SEARCHED

Minimum documentation searched (classification system followed by classification symbols)
 U.S. :

Documentation searched other than minimum documentation to the extent that such documents are included in the fields searched

Electronic data base consulted during the international search (name of data base and, where practicable, search terms used)
 East, STN, MEDLINE

C. DOCUMENTS CONSIDERED TO BE RELEVANT

Category *	Citation of document, with indication, where appropriate, of the relevant passages	Relevant to claim No.
Y	US 5,912,116 A (CALDWELL) 15 June 1999 (15.06.1999), whole document	1-90
Y	US 5,821,066 A (PYLE et al) 13 October 1998 (13.10.1998), whole document	1-90
Y	US 5,869,345 A (CHANDLER) 09 February 1999 (09.02.1999), whole document	1-90
Y,P	US 6,046,058 A (SUN) 04 April 2000 (04.02.2000), whole document	1-90

Further documents are listed in the continuation of Box C. See patent family annex.

Special categories of cited documents:	
"A" document defining the general state of the art which is not considered to be of particular relevance	"T" later document published after the international filing date or priority date and not in conflict with the application but cited to understand the principle or theory underlying the invention
"E" earlier application or patent published on or after the international filing date	"X" document of particular relevance; the claimed invention cannot be considered novel or cannot be considered to involve an inventive step when the document is taken alone
"L" document which may throw doubts on priority claim(s) or which is cited to establish the publication date of another citation or other special reason (as specified)	"Y" document of particular relevance; the claimed invention cannot be considered to involve an inventive step when the document is combined with one or more other such documents, such combination being obvious to a person skilled in the art
"O" document referring to an oral disclosure, use, exhibition or other means	"&" document member of the same patent family
"P" document published prior to the international filing date but later than the priority date claimed	

Date of the actual completion of the international search 14 August 2000 (14.08.2000)	Date of mailing of the international search report 30 AUG 2000
Name and mailing address of the ISA/US Commissioner of Patents and Trademarks Box PCT Washington, D.C. 20231 Facsimile No. (703)305-3230	Authorized officer Kartic Padmanabhan <i>Bella Cella for</i> Telephone No. 703-308-0196

INTERNATIONAL SEARCH REPORT

International application No.

PCT/US00/13056

Box I Observations where certain claims were found unsearchable (Continuation of Item 1 of first sheet)

This international report has not been established in respect of certain claims under Article 17(2)(a) for the following reasons:

1. Claim Nos.:
because they relate to subject matter not required to be searched by this Authority, namely:

2. Claim Nos.:
because they relate to parts of the international application that do not comply with the prescribed requirements to such an extent that no meaningful international search can be carried out, specifically:

3. Claim Nos.:
because they are dependent claims and are not drafted in accordance with the second and third sentences of Rule 6.4(a).

Box II Observations where unity of invention is lacking (Continuation of Item 2 of first sheet)

This International Searching Authority found multiple inventions in this international application, as follows:
Please See Continuation Sheet

1. As all required additional search fees were timely paid by the applicant, this international search report covers all searchable claims.
 2. As all searchable claims could be searched without effort justifying an additional fee, this Authority did not invite payment of any additional fee.
 3. As only some of the required additional search fees were timely paid by the applicant, this international search report covers only those claims for which fees were paid, specifically claims Nos.:

 4. No required additional search fees were timely paid by the applicant. Consequently, this international search report is restricted to the invention first mentioned in the claims; it is covered by claims Nos.:
- Remark on Protest The additional search fees were accompanied by the applicant's protest.
 No protest accompanied the payment of additional search fees.

INTERNATIONAL SEARCH REPORT

International application No.

PCT/US00/13056

BOX II. OBSERVATIONS WHERE UNITY OF INVENTION IS LACKING

Group I, claim(s) 1-79, drawn to a device for assaying a fluid sample.

Group II, claim(s) 80-90, drawn to a method for detecting or measuring the amount of a component of a fluid sample.

The inventions listed as Groups I and II do not relate to a single general inventive concept under PCT Rule 13.1 because, under PCT Rule 13.2, they lack the same or corresponding special technical features for the following reasons: the method of Group II can be practiced by various other devices including chromatography and NMR.

**This Page is Inserted by IFW Indexing and Scanning
Operations and is not part of the Official Record**

BEST AVAILABLE IMAGES

Defective images within this document are accurate representations of the original documents submitted by the applicant.

Defects in the images include but are not limited to the items checked:

- BLACK BORDERS
- IMAGE CUT OFF AT TOP, BOTTOM OR SIDES
- FADED TEXT OR DRAWING
- BLURRED OR ILLEGIBLE TEXT OR DRAWING
- SKEWED/SLANTED IMAGES
- COLOR OR BLACK AND WHITE PHOTOGRAPHS
- GRAY SCALE DOCUMENTS
- LINES OR MARKS ON ORIGINAL DOCUMENT
- REFERENCE(S) OR EXHIBIT(S) SUBMITTED ARE POOR QUALITY
- OTHER: _____

IMAGES ARE BEST AVAILABLE COPY.

As rescanning these documents will not correct the image problems checked, please do not report these problems to the IFW Image Problem Mailbox.

THIS PAGE BLANK (USPTO)